

# PHANTOM 4

User Manual V1.6

2017.07

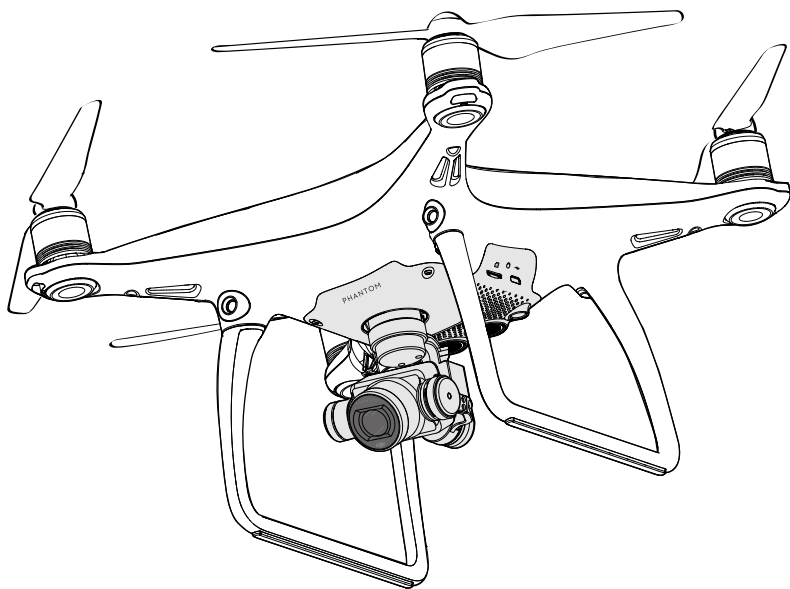

## Searching for Keywords

Search for keywords such as “battery” and “install” to find a topic. If you are using Adobe Acrobat Reader to read this document, press Ctrl+F on Windows or Command+F on Mac to begin a search.

## Navigating to a Topic

View a complete list of topics in the table of contents. Click on a topic to navigate to that section.

## Printing this Document

This document supports high resolution printing.

# Using this manual

## Legends

 Warning

 Important

 Hints and Tips

 Reference

## Read Before the First Flight

Read the following documents before using the PHANTOM™ 4:

1. *In the Box*
2. *Phantom 4 User Manual*
3. *Phantom 4 Quick Start Guide*
4. *Phantom 4 Disclaimer and Safety Guidelines*
5. *Phantom 4 Intelligent Flight Battery Safety Guidelines*

We recommend that you watch all tutorial videos on the official DJI™ website and read the Disclaimer before you fly. Prepare for your first flight by reviewing the Phantom 4 Quick Start Guide and refer to the User Manual for more details.

## Video Tutorials

Please watch the tutorial videos at the link below, which demonstrates how to use Phantom 4 safely:

<http://www.dji.com/product/phantom-4/info#video>



## Download the DJI GO 4 App

Be sure to use the DJI GO™ 4 app or other apps compatible with DJI aircraft during flight.

Scan the QR code on the right to download the latest version.

The Android version of the DJI GO 4 app is compatible with Android 4.4 or later.

The iOS version of the DJI GO 4 app is compatible with iOS 9.0 or later.



\* For increased safety, the flight is restricted to a height of 30 m and distance of 50 m when not connected or logged into the app during flight, including DJI GO 4 and all apps compatible with DJI aircraft.

# Contents

|  |    |
|--|----|
| <b>Using this manual</b>               | 2  |
| Legends                                | 2  |
| Read Before the First Flight           | 2  |
| Video Tutorials                        | 2  |
| Download the DJI GO 4 App              | 2  |
| <b>Product Profile</b>                 | 6  |
| Introduction                           | 6  |
| Features Highlights                    | 6  |
| Preparing the Aircraft                 | 6  |
| Aircraft Diagram                       | 8  |
| Remote Controller Diagram              | 8  |
| <b>Aircraft</b>                        | 11 |
| Flight Controller                      | 11 |
| Flight Mode                            | 11 |
| Flight Status Indicator                | 12 |
| Return-to-Home (RTH)                   | 13 |
| Intelligent Flight Mode                | 17 |
| Obstacle and Vision Positioning System | 25 |
| Detection Range                        | 25 |
| Calibrating Front Sensors              | 26 |
| Flight Recorder                        | 28 |
| Attaching and Detaching the Propellers | 28 |
| DJI Intelligent Flight Battery         | 29 |
| <b>Remote Controller</b>               | 35 |
| Remote Controller Profile              | 35 |
| Using the Remote Controller            | 35 |
| Remote Controller Status LED           | 39 |
| Linking the Remote Controller          | 40 |
| <b>Camera and Gimbal</b>               | 43 |
| Camera Profile                         | 43 |
| Gimbal                                 | 44 |

|                                       |    |
|---------------------------------------|----|
| <b>DJI GO 4 App</b>                   | 47 |
| Equipment                             | 47 |
| Editor                                | 50 |
| SkyPixel                              | 50 |
| Me                                    | 50 |
| <b>Flight</b>                         | 52 |
| Flight Environment Requirements       | 52 |
| Flight Limits and No-Fly Zones        | 52 |
| Preflight Checklist                   | 55 |
| Calibrating the Compass               | 56 |
| Auto Takeoff and Auto Landing         | 57 |
| Stop the motor mid-flight             | 58 |
| Starting/Stopping the Motors          | 58 |
| Flight Test                           | 59 |
| <b>FAQ</b>                            | 61 |
| <b>Appendix</b>                       | 65 |
| Specifications                        | 65 |
| Aircraft Status Indicator Description | 66 |
| Firmwares Update                      | 67 |
| Intelligent Flight Mode               | 67 |
| After-Sales Information               | 68 |
| FCC Compliance                        | 68 |

# Product Profile

---

This section introduces the Phantom 4 and lists the components of the aircraft and remote controller.

# Product Profile

## Introduction

The DJI Phantom 4 is an extremely smart flying camera able to intelligently track objects without a separate device, avoid obstacles and fly with a tap of your finger. All while shooting 4K video or 12 megapixel stills.

## Features Highlights

Tapfly and ActiveTrack are two brand new commands in the DJI GO 4 app, unique to the Phantom 4. Now with a simple tap you can fly anywhere visible on your screen or track a moving subject smoothly and easily.

**Camera and Gimbal:** With the Phantom 4, you're shooting 4K video at up to 30 frames per second and capturing 12 megapixel photos that look crisper and cleaner than ever. An enhanced sensor gives you greater clarity, lower noise, and better pictures than any previous flying camera.

**HD Video Downlink:** The low-latency long range (up to 5 km) HD downlink is powered by an enhanced version of DJI Lightbridge.

**DJI Intelligent Flight Battery:** The new 5350 mAh DJI Intelligent Flight Battery features upgraded battery cells and an advanced power management system to provide flight at up to around 28 minutes\*.

**Flight Controller:** The next-generation flight controller has been updated to provide a safer, more reliable flight experience. A newly implemented flight recorder stores critical data from each flight and the Vision Positioning System enhances hovering precision when flying indoors or in environments where GPS is unavailable. A dual IMUs and compasses design provides redundancy to the aircraft.

## Preparing the Aircraft

### Removing Gimbal Clamp

Remove the gimbal clamp from the camera as shown below:

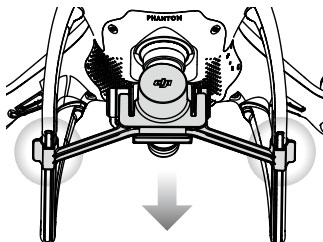

\*At sea level in calm environments when flying in ATTI mode, The flight time will vary due to different flight patterns, weather conditions and altitudes.

### Attaching the Propellers:

Mount the propellers with black propeller rings to the motors with black dots. Mount the propellers with silver propeller rings to the motors without black dots. Press the propeller down onto the mounting plate and rotate in the lock direction until it is secured in its position.

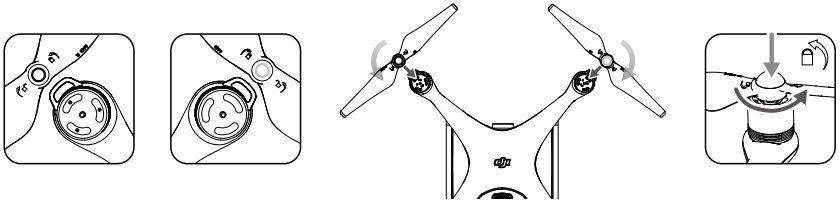

 Check that all the propellers are secure before each flight.

### Battery Installation

Slide battery into the battery compartment according to the arrow's direction shown below. Make sure that you hear a click sound indicates the battery is firmly installed. Failure to do so may affect the flight safety of your aircraft.

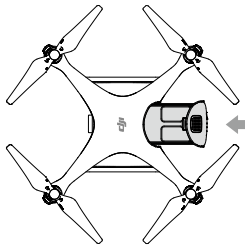

### Preparing the Remote Controller:

The mobile device holder is designed for securing tablet or mobile device. Tilt the mobile device holder to the desired position, then adjust the antennas so they are facing outward.

1. Press the button on the top right side of the mobile device holder to release the clamp, then adjust the clamp to fit the size of your mobile device.
2. Secure your mobile device in the clamp by pressing down, and connect your mobile device to the remote controller using a USB cable.
3. Plug one end of the cable into the mobile device, and the other end into the USB port on the back of the remote controller.

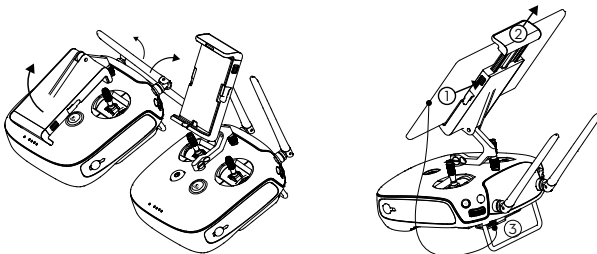

## Aircraft Diagram

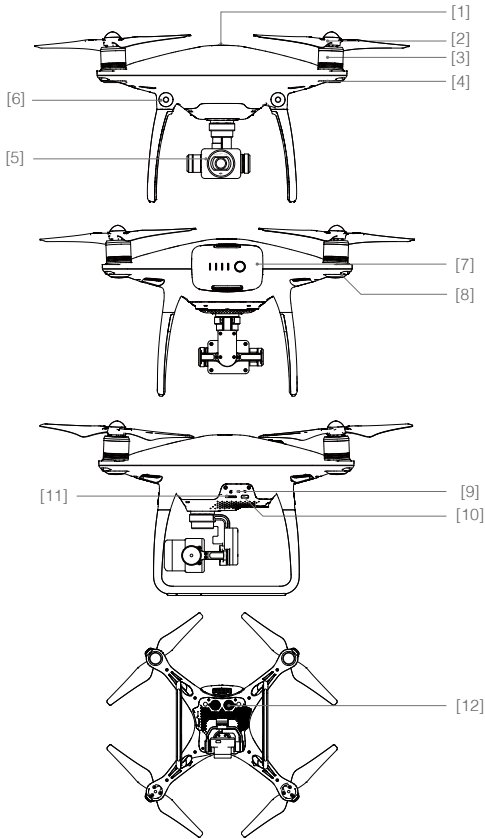

- [1] GPS
- [2] Propeller
- [3] Motor
- [4] Front LED Indicator
- [5] Gimbal and Camera
- [6] Obstacle Sensing System
- [7] Intelligent Flight Battery
- [8] Aircraft Status Indicator
- [9] Camera / Linking Status Indicator and Link Button
- [10] Micro USB Port
- [11] Camera Micro SD Card Slot
- [12] Vision Positioning Sensors

## Remote Controller Diagram

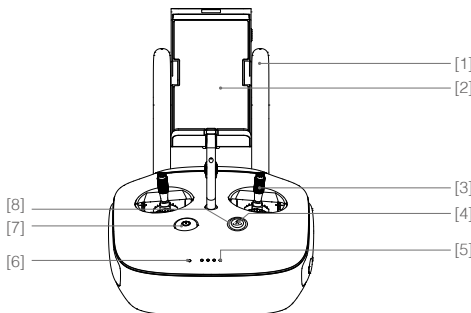

- [1] **Antennas**  
Relays aircraft control and video signal.
- [2] **Mobile Device Holder**  
Securely mounts your mobile device to the remote controller.
- [3] **Control Stick**  
Controls the orientation and movement of the aircraft.
- [4] **Return Home (RTH) Button**  
Press and hold the button to initiate Return to Home (RTH).



**[5] Battery Level LEDs**

Displays the battery level of the remote controller.

**[6] Status LED**

Displays the remote controller's system status.

**[7] Power Button**

Used to turn the remote controller on and off.

**[8] RTH LED**

Circular LED around the RTH button displays RTH status.

**[9] Camera Settings Dial**

Turn the dial to adjust camera settings.

(Only functions when the remote controller is connected to a mobile device running the DJI GO 4 app. )

**[10] Intelligent Flight Pause Button**

Press once to allow the aircraft to exit from TapFly, ActiveTrack and Advanced mode.

**[11] Shutter Button**

Press to take a photo. If burst mode is selected, the set number of photos will be taken with one press.

**[12] Flight Mode Switch**

Switch between P-mode, S-mode, and A-mode.

**[13] Video Recording Button**

Press to start recording video. Press again to stop recording.

**[14] Gimbal Dial**

Use this dial to control the tilt of the gimbal.

**[17] C1 Button**

Customizable through the DJI GO 4 app.

**[18] C2 Button**

Customizable through the DJI GO 4 app.

**[19] Power Port**

Connect to the Charger to charge the battery of the remote controller.

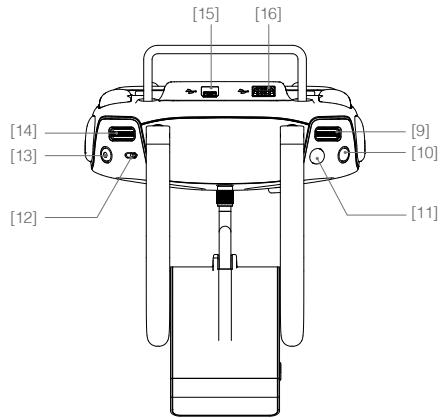
**[15] Micro USB Port**

Reserved port.

**[16] USB Port**

Connect to mobile device for running the DJI GO 4 app.

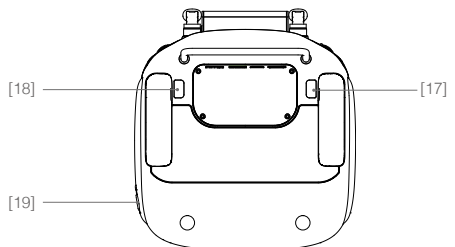

# Aircraft

---

This section introduces the features of the Flight Controller, Vision Positioning System, and the Intelligent Flight Battery

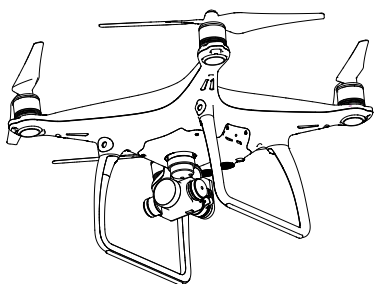

# Aircraft



## Flight Controller

The Phantom 4's flight controller features several important upgrades, including a new flight mode. Safety modes include Failsafe and Return-to-Home. These features ensure the safe return of your aircraft if the control signal is lost. The flight controller can also save critical flight data from each flight to the on-board storage device. The new flight controller also provides increased stability and a new air braking feature.

## Flight Mode

Three flight modes are available. The details of each flight mode are found below:

- P-mode (Positioning):** P-mode works best when the GPS signal is strong. The aircraft utilizes the GPS and Obstacle Sensing System to automatically stabilize itself, navigate between obstacles or track a moving object. Advanced features such as TapFly and ActiveTrack are enabled in this mode.
- S-mode (Sport):** The handling gain values of the aircraft are adjusted in order to enhance the maneuverability of the aircraft in S-mode. The maximum flight speed of the aircraft is increased to 20 m/s in this mode. Note that Obstacle Sensing system is disabled in this mode.
- A-mode (Attitude):** When neither the GPS nor the Obstacle Sensing System is available, the aircraft will only use its barometer for positioning to control the altitude.

- 
-  • **The Obstacle Sensing System is disabled in S-mode (Sport), which means the aircraft will not be able to automatically avoid obstacles in its flight path. Be vigilant and stay clear of nearby obstacles.**
- The aircraft's maximum speed and braking distance are significantly increased in S-mode (Sport). A minimum braking distance of 164 feet (50 meters) is required in windless conditions.
  - The aircraft's responsiveness is significantly increased in S-mode (Sport), which means a small stick movement on the remote controller will translate into a large travel distance of the aircraft. Be vigilant and maintain adequate maneuvering space during flight.
  - The aircraft's descent speed is significantly increased in S-mode (Sport). A minimum braking distance of 50 meters is required in windless conditions.
- 
-  • Use the Flight Controller mode switch to change the flight mode of the aircraft, refer to the "[Flight Mode Switch](#)" on Page 33 for more information.
-

## Flight Status Indicator

The Phantom 4 has Front LEDs and Aircraft Status Indicators. The positions of these LEDs are shown in the figure below:

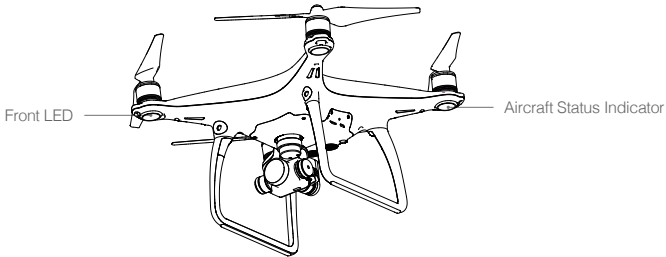

The Front LEDs show the orientation of the aircraft. The Front LEDs glow solid red when the aircraft is turned on to indicate the front (or nose) of the aircraft. The Aircraft Status Indicators communicate the system status of the flight controller. Refer to the table below for more information about the Aircraft Status Indicators.

### Aircraft Status Indicator Description

#### Normal

 ..... Red, Green and Yellow Flash Alternately  
Turning On and Self Diagnostic Testing

 ..... Green and Yellow Flash Alternately  
Warming Up

 ..... Green Flashes Slowly  
Safe to Fly (P-mode or S-mode with GPS , Vision Positioning and Obstacle Sensing)

 X2 ..... Green Flashes Twice  
Safe to Fly (P-mode or S-mode with GPS , Vision Positioning and Obstacle Sensing)

 ..... Yellow Flashes Slowly  
Safe to Fly (A-mode but No GPS and Vision Positioning and Obstacle Sensing)

#### Warning

 ..... Fast Yellow Flashing  
Remote Controller's Signal Lost

 ..... Slow Red Flashing  
Low Battery Warning

 ..... Fast Red Flashing  
Critical Battery Warning



 ..... Red Flashing Alternately  
IMU Error

 — Solid Red  
Critical Error

 ..... Red and Yellow Flash Alternately  
Compass Calibration Required

## Return-to-Home (RTH)

The Return-to-Home (RTH) function brings the aircraft back to the last recorded Home Point. There are three types of RTH procedures: Smart RTH, Low Battery RTH, and Failsafe RTH. This section describes these three scenarios in detail.

|  | GPS   | Description  |
|---|---|--|
| Home Point  |  | If a strong GPS signal was acquired before takeoff, the Home Point is the location from which the aircraft was launched. The GPS signal strength is indicated by the GPS icon (  ). The aircraft status indicator will blink rapidly when the home point is recorded. |

-  • Aircraft can sense and avoid obstacles when Obstacle Sensing System is enabled and the lighting conditions is sufficient. The aircraft will automatically climb up to avoid obstacle and fly to the Home Point at the new altitude.

### Failsafe RTH

The Forward Vision System allows the aircraft to create a real-time map of its flight route as it flies. If the Home Point was successfully recorded and the compass is functioning normally, Failsafe RTH will be automatically activated if the remote controller signal is lost for more than three seconds. The aircraft will plan its return route and retrace its original flight route home. The aircraft will hover for 10 seconds at its current location. When it regains signal connection it will wait for pilot commands. The Return-to-Home process may be interrupted and the pilot given control of the aircraft if the remote controller signal connection is re-established.

### Failsafe Illustration

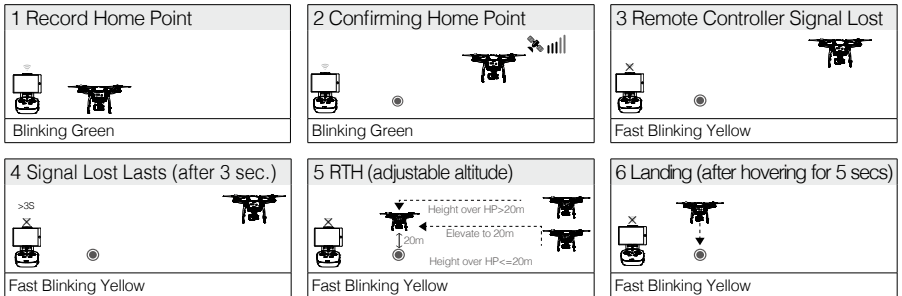

- ⚠ Aircraft cannot return to the Home Point when GPS signal is weak ( [ 📶 ] displays grey) or unavailable.
- Aircraft automatically descends and lands if RTH is triggered when the aircraft flies within a 20 meters (65 feet) radius of the Home Point. Aircraft will stop ascending and immediately return to the Home Point if you move the left stick if the aircraft reaches 20 meters (65 feet) altitudes or beyond during Failsafe.
- The aircraft cannot avoid obstruction during the Failsafe RTH when Obstacle Sensing system is disabled, therefore, it is important to set a suitable Failsafe altitude before each flight. Launch the DJI GO 4 app and enter “Camera” and select “MODE > Advanced Settings > Failsafe mode” to set the Failsafe altitude.
- User cannot control the aircraft while the aircraft is ascending to its failsafe altitude. However, user can press RTH button once to exit ascending and regain control.

## Smart RTH

Use the RTH button on the remote controller (refer to “[RTH button](#)” on page 33 for more information) or tap the RTH button in the DJI GO 4 app and follow the on-screen instructions when GPS is available to initiate Smart RTH. The aircraft will then automatically return to the last recorded Home Point. You may use the remote controller’s control sticks to control the aircraft’s position to avoid a collision during the Smart RTH process. Press and hold the Smart RTH button once to start the process, and press the Smart RTH button again to terminate the procedure and regain full control of the aircraft.

## Low Battery RTH

The low battery level failsafe is triggered when the DJI Intelligent Flight Battery is depleted to a point that may affect the safe return of the aircraft. Users are advised to return home or land the aircraft immediately when prompted. The DJI GO 4 app will display a notice when a low battery warning is triggered. The aircraft will automatically return to the Home Point if no action is taken after a ten-second countdown. The user can cancel the RTH procedure by pressing the RTH button on the remote controller. If the RTH procedure is cancelled following a low battery level warning the Intelligent Flight Battery may not have enough charge for the aircraft to land safely, which may lead to the aircraft crashing or being lost. The thresholds for these warnings are automatically determined based on the aircraft’s current altitude and distance from the Home Point.

The aircraft will land automatically if the current battery level can only support the aircraft long enough to descend from its current altitude. The user cannot cancel the auto landing but can use the remote controller to alter the aircraft’s orientation during the landing process.

The Battery Level Indicator is displayed in the DJI GO 4 app, and is described below:

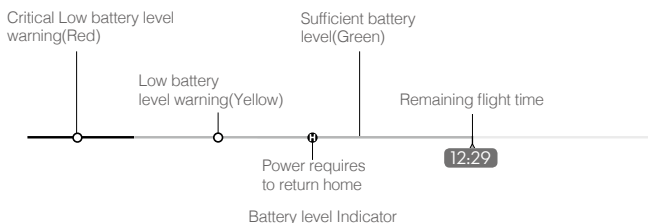

| Battery Level Warning              | Remark   | Aircraft Status Indicator                     | DJI GO 4 App  | Flight Instructions  |
|------------------------------------|--|---|---|--|
| Low battery level warning          | The battery power is low. Please land the aircraft.        | Aircraft status indicator blinks RED slowly.  | Tap "Go-home" to have the aircraft return to the Home point and land automatically, or "Cancel" to resume normal flight. If no action is taken, the aircraft will automatically go home and land after 10 seconds. Remote controller will sound an alarm. | Fly the aircraft back and land it as soon as possible, then stop the motors and replace the battery. |
| Critical Low battery level warning | The aircraft must land immediately.                        | Aircraft status indicator blinks RED quickly. | The DJI GO 4 app display will flash red and the aircraft will start to descend. The remote controller will sound an alarm.  | Allow the aircraft to descend and land automatically.  |
| Estimated remaining flight time    | Estimated remaining flight based on current battery level. | N/A   | N/A   | N/A  |



- When Critical battery level warning is triggered and the aircraft begins to land automatically, you may push the left stick upward to make the aircraft hover at its current altitude, giving you an opportunity to navigate to a more appropriate landing location.
- The colored zones and markers on the battery level indicator bar reflect the estimated remaining flight time. They are automatically adjusted according to the aircraft's current location and status.

## Precision Landing

The Phantom 4 automatically scans and attempts to match the terrain features underneath during Return to Home. When current terrain matches home point terrain, the Phantom 4 will start landing immediately to achieve precision landing. The DJI GO 4 app will show a terrain feature mismatch prompt if matching fails.



- Precision Landing performance is subject to the following conditions:
  - a) Home point is recorded upon take off, and cannot not be refreshed during flight.
  - b) Aircraft must take off vertically. Take off altitude must be greater than 7 meters.
  - c) Home point terrain features remain largely unchanged.
  - d) Home point terrain with no distinctive features will affect the performance.
  - e) Lighting conditions cannot be too light nor too dark.
- The following actions are available during landing:
  - a) Pull throttle down to accelerate landing.
  - b) Moving the control sticks in any other direction will stop Precision Landing. The Phantom 4 will descend vertically and Landing Protection will remain active.

## Failsafe Safety Notices

|  |  |
|--|--|
|  | The aircraft cannot avoid obstruction during the Failsafe RTH when the Obstacle Sensing System is disabled. Therefore, it is important to set an suitable Failsafe altitude before each flight. Launch the DJI GO 4 app and enter "Camera" and select "MODE > Advanced Settings > Failsafe mode" to set the Failsafe altitude.   |
|  | If the aircraft is flying under 20 meters (65 feet) and Failsafe (including Smart RTH, Lower Battery RTH ) is triggered, the aircraft will first automatically ascend to 20 meters (65 feet) from the current altitude. You can only cancel the ascending by exiting the Failsafe. Refer to " <u>RTH Button</u> " on page 33 for more information on how to exit the Failsafe and regain the control of the remote controller. |
|  | Aircraft automatically descends and lands if RTH is triggered when the aircraft flies within a 20 meters (65 feet) radius of the Home Point. Aircraft will stop ascending and immediately return to the Home Point if you move the left stick if the aircraft reaches 20 meters (65 feet) altitudes or beyond during Failsafe.   |
|  | Aircraft cannot return to the Home Point when GPS signal is weak ( [ 📶 ] displays grey) or unavailable.  |
|  | if you move the left stick after the aircraft rises above 65 feet (20m) but below the pre-set Failsafe RTH altitude, the aircraft will stop ascending and immediately return to the Home Point.  |

## Obstacle Avoidance During RTH

Aircraft can now sense and actively attempt to avoid obstacle during FailSafe RTH, provided that the light condition is ideal for the Obstacle Sensing System. The details on how the aircraft will behave during obstacle avoid is listed below:

1. Aircraft decelerates when an obstacle is sensed at 49 feet (15 meters) ahead.
2. Aircraft stops and hover then start ascending vertically to avoid the obstacle. Eventually, the aircraft will stop climbing when it is at least 16 feet (5 meters) above the detected obstacle.
3. Failsafe RTH procedure resume, the aircraft will continue flying to the Home Point at the current altitude.

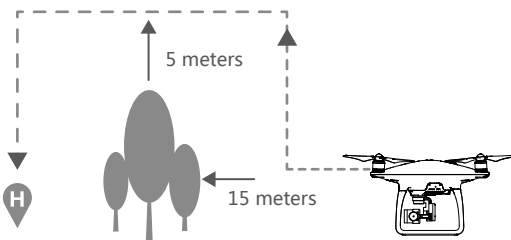



- 
- ⚠ • To ensure the aircraft is heading towards the static direction, you cannot rotate the aircraft during FailSafe RTH while Obstacle Sensing System is enabled.
  - The aircraft cannot avoid the obstacle that is direct above the aircraft.
- 

## Landing Protection Function

Landing Protection will activate during auto landing.

1. Landing Protection determines whether the ground is suitable for landing. If so, the Phantom 4 will land gently.
  2. If Landing Protection determines that the ground is not suitable for landing, the Phantom 4 will hover and wait for pilot confirmation. The aircraft will hover if it detects the ground is not appropriate for landing even with a critically low battery warning. Only when the battery level decreases to 0% will the aircraft land. Users retain control of aircraft flight orientation.
  3. If Landing Protection is inactive, the DJI GO 4 app will display a landing prompt when the Phantom 4 descends below 0.3 meters. Tap to confirm or pull down the control stick for 2 seconds to land when the environment is appropriate for landing.
- 

- ⚠ • Landing Protection will not be active in the following circumstances:
    - a) When the user is controlling the pitch/roll/throttle sticks (Landing ground detection will re-activate when control sticks are not in use)
    - b) When the positioning system is not fully functional (e.g. drift position error)
    - c) When the downward vision system needs re-calibration
    - d) When light conditions are not sufficient for the downward vision system
  - If an obstacle is within 1-meter of the aircraft, the aircraft will descend to 0.3 m above the ground and hover. The aircraft will land upon with user confirmation.
- 

## Intelligent Flight Mode

When an Intelligent Flight Mode is enabled, the gimbal camera will record vision system image data and store it in the flight data record system. It will stop recording when the Intelligent Flight Mode is disabled. Vision system image data is used to help improve Intelligent Flight Mode security and accuracy by matching it to its data history.

### TapFly

#### Introduction

With the TapFly feature, user now can tap on the mobile device screen to guide the aircraft to fly toward the designated direction without using the remote controller. Aircraft can automatically avoid obstacle or initiate break and then hover automatically during the flight, provided that the lighting is not too dark ( < 300 lux) nor too bright ( > 10,000 lux).

#### Using TapFly

Ensure the battery level is more than 50 % for the Intelligent Flight Battery. And the aircraft is in P-mode. Then follow the steps below to use TapFly:

Take off and ensure the aircraft is flying at least 9 feet (3 meters) above the ground.

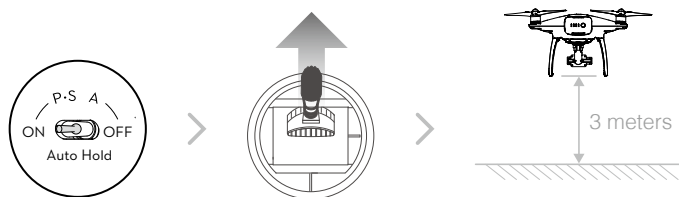

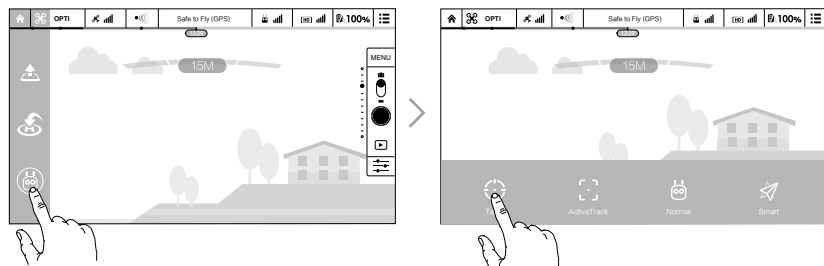

Launch DJI GO 4 app and tap  at the bottom of the camera view, read and understand the prompt statements.

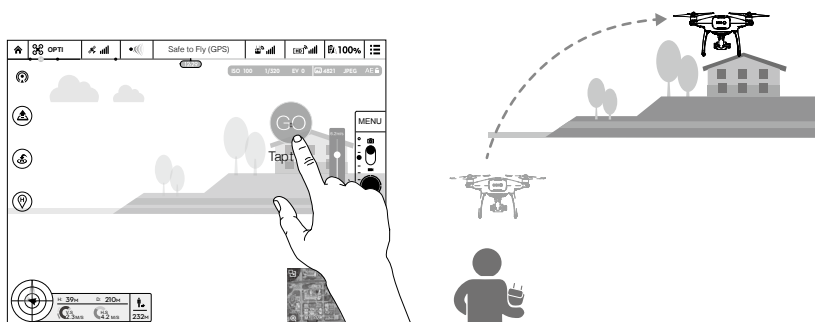

Tap once on the target direction and wait for  icon to appear. Tap again to confirm the selection and the aircraft will automatically fly towards the target direction.



-  • DO NOT guide the aircraft to fly towards people, animals, small and fine objects (e.g. tree branches and power lines) or transparent objects (e.g. glass or water surface).
- Watch for the obstacles that is on the flight path and stay clear of them.
  - There may be deviations between the expected and the actual flight path of TapFly selection.
  - The selectable range for the target direction is limited. You cannot make TapFly selection that is close to the upper or lower edge of the screen.
  - TapFly mode may not work properly when the aircraft is flying over water surface or snow covered area.
  - Be extra cautions when flying in extremely dark (< 300 lux ) or bright (>10,000 lux) environments.

After confirmed with the TapFly selection, the aircraft will fly automatically towards the area marked by  icon. Note that you can still use the control stick to control the movement of the aircraft during the flight.

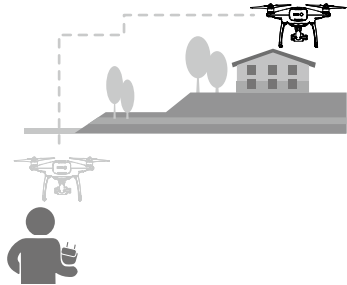
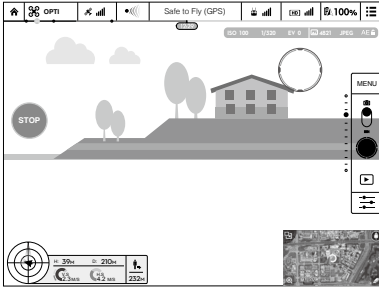

Note that the aircraft will also automatically adjust its speed when it senses there is obstacle at the front of the aircraft or it is flying too close to the ground. However, the user should not rely on this feature to navigate the aircraft between the obstacles. Meanwhile the FailSafe procedure will override the TapFly operation, given that if the GPS signal is weak; the aircraft will exit the autonomous flight from TapFly and fly back to the Home Point automatically.

TapFly includes following functions:

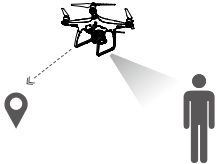
| TapFly Forward Mode  | Free Mode  |
|--|--|
|  |    |
| <p>The aircraft will fly towards the target. Forward Vision System is active.</p>  | <p>The aircraft will fly towards the target. The remote controller can be used to maneuver the yaw of the aircraft freely. Obstacle Sensing is disabled in this mode, use it in an unobstructed environment.</p> |

### Exit TapFly

Use the following methods to exit TapFly:

1. Press once on the Intelligent Flight Pause button on the remote controller or pull back the pitch stick on the remote controller.
2. Tap "STOP" button on the screen.

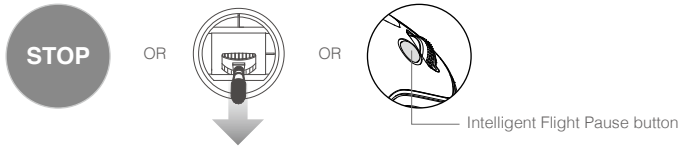

Aircraft will stop and hover after exit from TapFly. You may either tap a new target direction to proceed to the next flight or bring back the aircraft to the Home Point manually.

### ActiveTrack

ActiveTrack allows you to mark and track a moving object on your mobile device screen. The aircraft will automatically avoid obstacles in its flight path.

#### Using ActiveTrack

Ensure the Intelligent Flight Battery has more than 50% power and the aircraft is in either P-mode. Then follow the steps below to use ActiveTrack:

1. Take off and hover at least 9 feet (3 meters) above the ground.

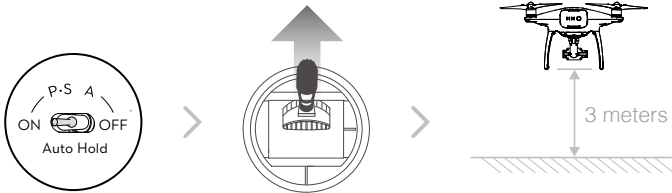

2. In the DJI GO 4 app, tap  to bring up the flight modes and then select.

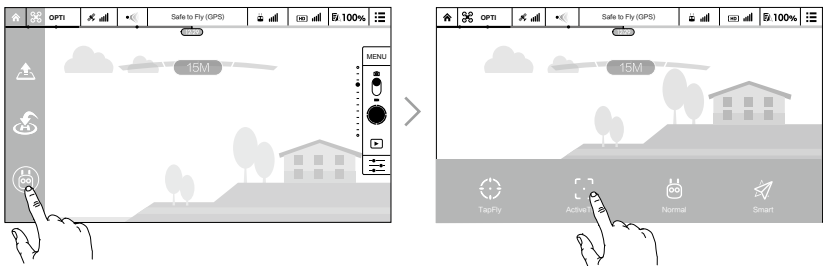



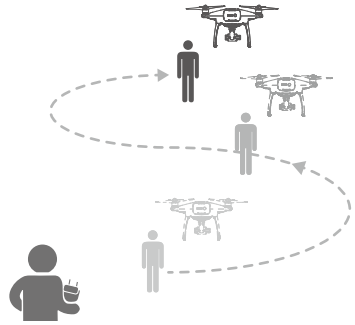
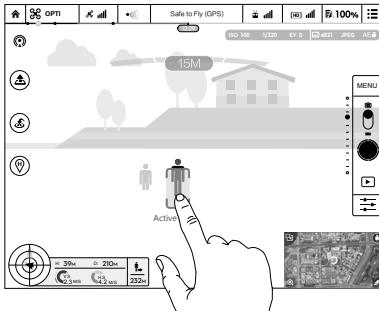

3. Drag a box around the object you want to track and tap it to confirm the selection. The box will turn green when tracking is in progress. If the box turns red, the object was not identified and you should try again.

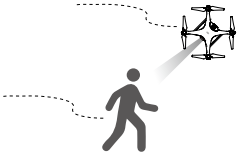

ActiveTrack includes following functions:

| Trace   | Spotlight   | Profile  |
|---|---|--|
|   |    |   |
| <p>The aircraft tracks the subject at a constant distance. Use the roll stick on the remote controller or the slider in DJI GO to circle the subject.</p> | <p>Aircraft will not trace a subject automatically, but it keeps the camera pointing at the subject during flight. The remote controller can be used to maneuver the aircraft, but yaw is disabled. Using the left stick and gimbal dial will adjust subject framing.</p> | <p>The aircraft tracks the subject at constant angle and distance from the side. Use the roll stick on the remote control to circle the subject.</p> |

- ⚠️ • DO NOT select an area containing people, animals, small, fine objects (e.g. tree branches and power lines) or transparent objects (e.g. glass or water surface).
  - Stay clear of obstacles near the flight path, particularly when the aircraft is flying backward.
  - Be extra vigilant when using ActiveTrack in any of the following situations:
    - a) The tracked subject is not moving on a level plane.
    - b) The tracked subject changes shape drastically while moving.
    - c) The tracked subject could be blocked or out of sight for a long time.
    - d) The tracked subject is moving on a snowy surface.
    - e) The lighting is extremely low (< 300 lux) or high (> 10,000 lux).
    - f) The tracked subject has a similar color or pattern as its surrounding environment.
  - You must follow local privacy laws and regulations when using ActiveTrack.
- 
- ☀️ • The aircraft will sense and avoid obstacles on its flight path.
  - If the aircraft loses track of the subject, because it is moving too fast or obscured, re-select the subject to resume tracking.
- 

### Exiting ActiveTrack

There are two ways to exit ActiveTrack:

1. Press the Intelligent Flight Pause button on the remote controller.
2. Pull the pitch stick backward.

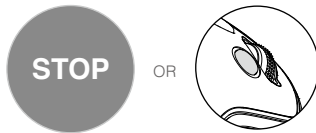

After exiting ActiveTrack, the aircraft will stop and hover in place, at which point you may choose to start a new mission or bring the aircraft back to the Home Point.

### Draw

#### Introduction



Using Draw, the aircraft will fly along the flight path drawn on-screen. As it flies it will automatically brake and hover when it sees obstacles provided that the lighting is appropriate - no darker than 300 lux nor brighter than 10,000 lux.

#### Using Draw

Ensure the aircraft is in P-mode, then follow the steps below to use Draw:

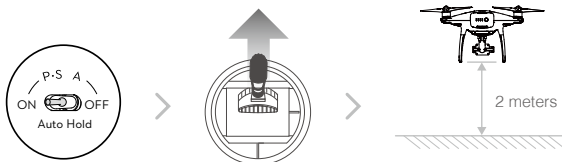
1. Take off and hover at least 6 feet (2 meters) above the ground.



2. Launch the DJI GO 4 app and tap , then tap , read and understand the prompts.

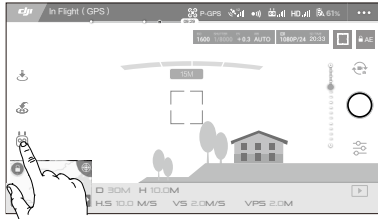

3. Draw a line on the screen to create a path. Tap  and the aircraft will fly along the path.

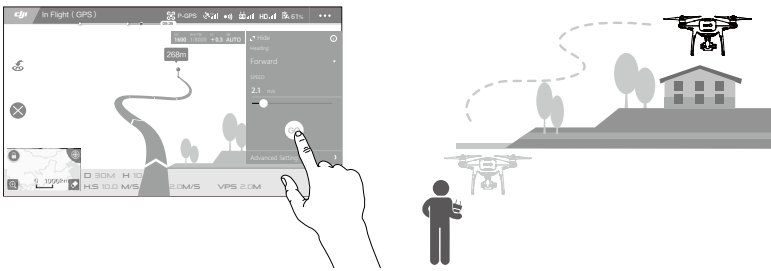

-  • DO NOT fly the aircraft towards people, animals, or small/fine objects (e.g. tree branches and power lines) or transparent objects (e.g. glass or water).
- There may be some deviation between the expected and the actual flight path.

After confirming the flight path, the aircraft will fly along the path on-screen. Note: Control sticks can be used to control aircraft movement during the flight.

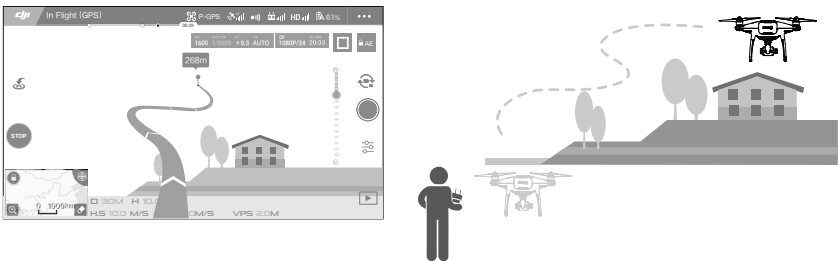

The aircraft will automatically adjust its speed when it senses an obstacle in front or if it is flying too close to the ground. However, this feature should not be relied upon for navigation between obstacles. Failsafe procedures will override Draw. If the GPS signal weakens, the aircraft will exit autonomous flight and return to home.

## Exit Draw

Use the following methods to exit Draw:

1. Tap the "STOP" button on the screen.
2. Pull back the pitch stick on the remote controller and hold for more than 3s.
3. Press the Intelligent Flight Pause button on the remote controller.

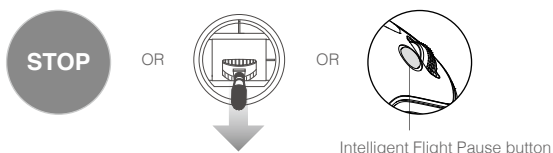

Aircraft will stop and hover after exiting from Draw. Draw a new flight path to continue flying or begin manual flight.

## Gesture Mode

In Gesture Mode, the Phantom 4 Advanced / Advanced+'s Vision System recognizes gestures, allowing it to follow and capture selfies without a phone or a controller. Follow the steps below to use Gesture Mode:

| Modes                   | Prompts | Front LEDs                    | Remarks   |
|-------------------------|---------|-------------------------------|---|
| 1. Confirm the subject  |         | .....<br>Slow Red Flashing    | Ensure the forward vision system is active and there is enough light. Tap the icon and move in front of the camera for the Phantom 4 Advanced / Advanced+ to recognize you. |
| 2. Confirm the distance |         | x2 .....<br>Red Flashes Twice | Raise your arms and wave to the Phantom 4 Advanced / Advanced+, the Front LEDs will blink red twice once it confirms the shooting distance.                                 |
| 3. Selfie Count Down    |         | .....<br>Fast Red Flashing    | Put your fingers in front on your face as shown.  |



- Gesture Mode can only be used in Photo Mode.
- Fly the aircraft 2 meters or higher above the ground then move in front of the camera to be recognized. Front LED Indicators will blink red rapidly if the Phantom 4 Advanced / Advanced+ fails to recognize a subject.
- Enabling GPS on your phone will allow the Phantom 4 Advanced / Advanced+ to follow with more accuracy while flying in Gesture Mode.

## Tripod Mode

Tap the icon in the DJI GO 4 app to enable Tripod Mode. In Tripod Mode, the maximum flight speed is limited to 5.6 mph (9 kph) and the braking distance is reduced to 6.6 ft (2 m). Responsiveness to stick movements is also reduced for smoother more controlled movements.



-  • Only use Tripod Mode where the GPS signal is strong or light conditions are ideal for the vision system. If GPS signal is lost and the vision system cannot function, it will automatically switch to Atti mode. In this case, flight speed will increase and the aircraft cannot hover in place. Use Tripod Mode carefully.

### Terrain Follow Mode

The Downward Vision System is utilized in Terrain Follow Mode to maintain a height above ground between 1 and 10 meters. This mode is designed for use on grassland sloped at no more than 20°. Enable the Terrain Follow Mode by tapping the Intelligent Flight Mode icon in the DJI GO 4 app. When this mode is enabled, the aircraft's current height will be recorded. The aircraft will maintain the recorded height during flight and ascend when the slope rises. However, the aircraft will not descend in downward slopes.

-  • It is important that you only fly in conditions where the Vision Position System can function correctly; otherwise the Terrain Follow Mode will not work.

## Obstacle and Vision Positioning System

The Phantom 4 is equipped with an Obstacle Sensing System that constantly scans for obstacles in front of it, allowing it to avoid collisions by going around, over or hovering. The DJI Vision Positioning System uses ultrasound and image data to help the aircraft maintain its current position. With the help of Vision Positioning, your Phantom 4 can hover in place more precisely and fly indoors or in other environments where a GPS signal is not available. The main components of the Vision Positioning System are located on the bottom of your Phantom 4; they include [3] two ultrasonic sensors and [1] [2] four monocular sensors. When you turn on the aircraft, the vision system will record the flight environment and will store its vision system image data in the flight data record system. Vision system image data is used to improve the performance of positioning reliability and accuracy by matching it to current real-time environments.

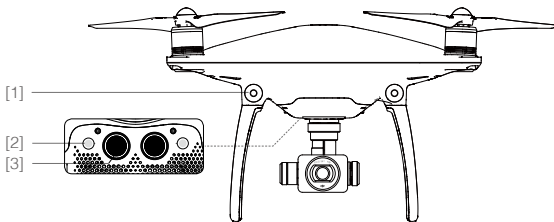

### Detection Range

The detection range of the Obstacle Sensing and Vision Positioning System is depicted as follow. Note that the aircraft cannot sense and avoid the obstacles that are not within the detection range.

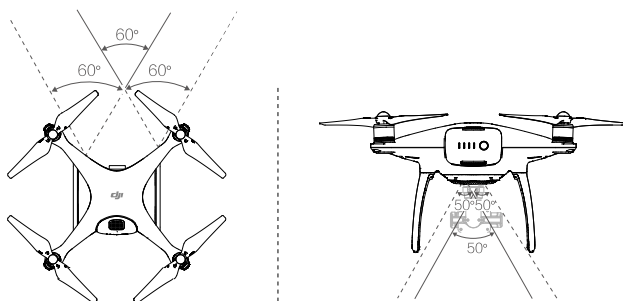

## Calibrating Front Sensors

Obstacles Sensing cameras that installed on landing gear are calibrated on delivery. However these camera are vulnerable to excessive impact, hence it will require calibration via DJI Assistant 2 from time to time. Follow the steps below to calibrate the camera when the DJI GO 4 app prompt you to do so.

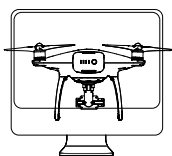

01

Point the aircraft toward the screen

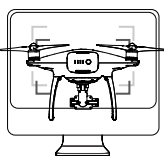

02

Align the boxes

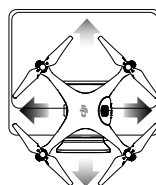

03

Pan and tilt the aircraft

## Using Vision Positioning

Vision Positioning is activated automatically when the aircraft is turned on. No further action is required. Vision Positioning is typically used in indoor environments, where GPS is unavailable. Using the sensors that are built into the Vision Positioning system, the aircraft can hover precisely even without GPS.

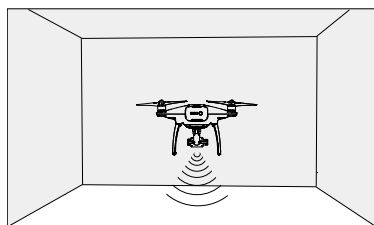

Follow the steps below to use Vision Positioning:

1. Toggle the flight mode switch to P-mode.
2. Place the aircraft on a flat surface. Note that the Vision Positioning system cannot work properly on surfaces without clear pattern variations.
3. Turn on the aircraft. The aircraft status indicator will flash green two times, which indicates the Vision Positioning system is ready. Gently push the left stick up to lift off and the aircraft will hover in place.

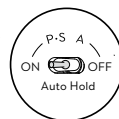

### Assisted Braking from Obstacle Sensing System

Powered by the Obstacle Sensing System, the aircraft will now be able to actively initiate breaks when obstacles are detected direct ahead of the aircraft. Note that Obstacle System works best when light condition is ideal and the obstacle does not have feature-less pattern. In addition, the aircraft speed cannot exceed over 10 meter/second so that the aircraft can break and stop at the safe distance.

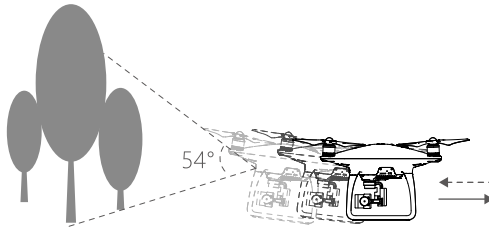

**⚠** The performance of your Vision Positioning System is affected by the surface over which it is flying. The ultrasonic sensors may not be able to accurately measure distances when operating above sound-absorbing materials. In addition, the camera may not function correctly in suboptimal environments. The aircraft will switch from P-mode to A-mode automatically if neither GPS nor Vision Positioning System are available. Operate the aircraft with great caution in the following situations:

- Flying over monochrome surfaces (e.g. pure black, pure white, pure red, pure green).
- Flying over a highly reflective surfaces.
- Flying at high speeds (over 10 m/s at 2 meters or over 5 m/s at 1 meter).
- Flying over water or transparent surfaces.
- Flying over moving surfaces or objects.
- Flying in an area where the lighting changes frequently or drastically.
- Flying over extremely dark ( $\text{lux} < 10$ ) or bright ( $\text{lux} > 100,000$ ) surfaces.
- Flying over surfaces that can absorb sound waves (e.g. thick carpet).
- Flying over surfaces without clear patterns or texture.
- Flying over surfaces with identical repeating patterns or textures (e.g. tiles with the same design).
- Flying over inclined surfaces that will deflect sound waves away from the aircraft.

- ☀**
- Keep the sensors clean at all times. Dirt or other debris may adversely affect the effectiveness of the sensors.
  - Vision Positioning is only effective when the aircraft is at altitudes of 0.3 to 10 meters.
  - The Vision Positioning System may not function properly when the aircraft is flying over water.
  - The Vision Positioning System may not be able to recognize pattern on the ground in low light conditions (less than 100 lux).
  - Do not use other ultrasonic devices with frequency of 40 KHz when Vision Positioning system is in operation.





- ⊘**
- Keep the animals away from the aircraft when Vision Positioning system is activated. The sonar sensor emits high frequency sounds that are only audible to some animals.

## Flight Recorder

Flight data is automatically recorded to the internal storage of the aircraft. You can connect the aircraft to a computer via the USB port and export this data via DJI Assistant 2. This includes data for the sensors, navigation system, devices, aircraft control, no-fly zones, and vision system images. Note that all data is encoded and only stored on your DJI device. Data does not upload to a DJI server automatically, nor is it shared with DJI in any other way.

## Attaching and Detaching the Propellers

Use only DJI approved propellers with your Phantom 4. The grey and black ring on the propeller indicate where they should be attached and in which direction they should spin.

| Propellers | Silver Ring  | Black Ring  |
|------------|--|---|
| Figure     |   |  |
| Attach On  | Motors without three dots  | Motors with three dots  |
| Legends    |  Lock : Turn the propellers in the indicated direction to mount and tighten.<br> Unlock : Turn the propellers in the indicated direction to loosen and remove. |   |

### Attaching the Propellers

1. Be sure to remove the warning stickers from the motors before attaching the propellers.
2. Mount the propellers with black propeller rings to the motors with black dots. Mount the propellers with silver propeller rings to the motors without black dots. Press the propeller down onto the mounting plate and rotate in the lock direction until it is secured in its position.

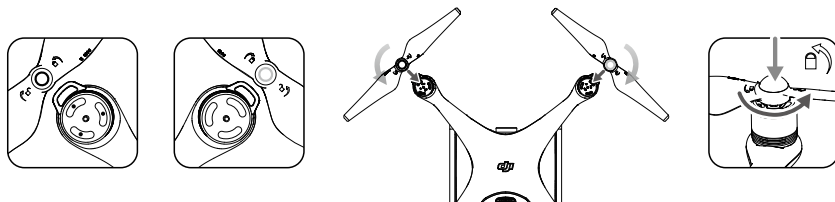

- Be aware of the sharp edges of the propellers. Handle with care.
- Use only the DJI approved propellers. Do not intermix the propellers types.
- Stand clear of the motors and DO NOT touch the propellers when they are spinning.

## Detaching the Propellers

Press down the propellers onto the motor mount, rotate the propeller according to the marked direction to unlock the propeller.

- ⚠ • Check that the propellers and motors are installed correctly and firmly before every flight.
- Ensure that all propellers are in good condition before each flight. DO NOT use aged, chipped, or broken propellers.
- To avoid injury, STAND CLEAR of and DO NOT touch propellers or motors when they are spinning.
- ONLY use original DJI propellers for a better and safer flight experience.

## DJI Intelligent Flight Battery

The DJI Intelligent Flight Battery has a capacity of 5350 mAh, a voltage of 15.2 V, and a smart charge/discharge functionality. It should only be charged using an appropriate charger that has been approved by DJI.

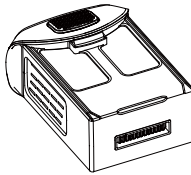

Intelligent Flight Battery

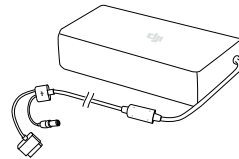

Charger

- ⚠ The Intelligent Flight Battery must be fully charged before using it for the first time. Refer to ["Charging the Intelligent Flight Battery"](#) for more information.

- ⚡ Be aware that the output power of the supplied Phantom 4 charger is 100W.

## DJI Intelligent Flight Battery Functions

1. Battery Level Display: The LED indicators display the current battery level.
2. Battery Life Display: The LEDs display the current battery power cycle.
3. Auto-Discharging Function: To prevent swelling, the battery automatically discharges to below 65% of total power when it is idle for more than ten days. It takes around two days to discharge the battery to 65%. It is normal to feel moderate heat being emitted from the battery during the discharge process. Discharge thresholds can be set in the DJI GO 4 app.
4. Balanced Charging: Automatically balances the voltage of each battery cell when charging.
5. Overcharge Protection: Charging automatically stops when the battery is fully charged.
6. Temperature Detection: The battery will only charge when the temperature is between 5°C (41°F) and 40°C (104°F).
7. Over Current Protection: The battery stops charging when high amperage (more than 8 A) is detected.
8. Over Discharge Protection: To prevent over-discharge damage, discharging automatically stops when the battery voltage reaches 12 V.
9. Short Circuit Protection: Automatically cuts the power supply when a short circuit is detected.

10. Battery Cell Damage Protection: The DJI GO 4 app displays a warning message when a damaged battery cell is detected.
11. Battery Error History: Browse the battery error history in the DJI GO 4 app.
12. Sleep Mode: To save power, the battery enters sleep mode after 20 minutes of inactivity.
13. Communication: Information pertaining to the battery's voltage, capacity, current, etc. is transmitted to the aircraft's main controller.

 Refer to *Phantom 4 Intelligent Flight Battery Safety Guidelines* before use. Users take full responsibility for all operations and usage.

## Using the Battery

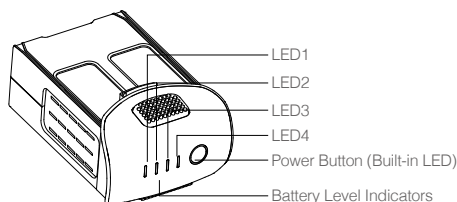





































### Turning ON/OFF

**Turning On:** Press the Power Button once, then press again and hold for 2 seconds to turn on. The Power LED will turn red and the Battery Level Indicators will display the current battery level.

**Turning Off:** Press the Power Button once, then press again and hold for 2 seconds to turn off. The battery power LED will flash when powering off the Phantom to allow automatically stopping of a recording during the event recording wasn't stopped.

 The Battery Level Indicators will also show the current battery level during charging and discharging. The indicators are defined below.

 : LED is on.       : LED is flashing.  
 : LED is off.

| Battery Level   |   |   |   |               |
|---|---|---|---|---------------|
| LED1  | LED2  | LED3  | LED4  | Battery Level |
|  |  |  |  | 87.5%~100%    |
|  |  |  |  | 75%~87.5%     |
|  |  |  |  | 62.5%~75%     |
|  |  |  |  | 50%~62.5%     |
|  |  |  |  | 37.5%~50%     |
|  |  |  |  | 25%~37.5%     |
|  |  |  |  | 12.5%~25%     |
|  |  |  |  | 0%~12.5%      |
|  |  |  |  | =0%           |

**Low Temperature Notice:**

1. Battery capacity is significantly reduced when flying in low temperature (< 0°C) environments.
2. It is not recommended that the battery be used in extremely low temperature (< -10°C) environments. Battery voltage should reach the appropriate level when operating environment with temperatures between -10°C and 5°C.
3. End the flight as soon as the DJI GO 4 app displays the "Low Battery Level Warning" in low temperature environments.
4. Keep the battery indoors to warm it before flying in low temperature environments.
5. To ensure optimal performance of the battery, keep the battery temperature above 20°C.
6. The charger will stop charging the battery if the battery cell's temperature is not within the operating range (0°C ~ 40°C).





































 In cold environments, insert the battery into the battery compartment and allow the aircraft for approximately 1-2 minutes to warm up before taking off.

**Checking the Battery Level**

The Battery Level Indicators display how much power remains. When the battery is turned off, press the Power Button once. The Battery Level Indicators will light up to display the current battery level. See below for details.

**Battery life**

Battery life refers to how many more times the battery can be discharged and recharged before it must be replaced. When the battery is turned off, press and hold the Power Button for 5 seconds to check the battery life. The Battery Level Indicators will light up and/or blink for two seconds, as shown below:

| Battery Life  |   |   |   |              |
|---|---|---|---|--------------|
| LED1  | LED2  | LED3  | LED4  | Battery Life |
|    |    |    |    | 90%~100%     |
|    |    |    |    | 80%~90%      |
|   |   |   |   | 70%~80%      |
|  |  |  |  | 60%~70%      |
|  |  |  |  | 50%~60%      |
|  |  |  |  | 40%~50%      |
|  |  |  |  | 30%~40%      |
|  |  |  |  | 20%~30%      |
|  |  |  |  | below 20%    |

 When battery life reaches 0%, it can no longer be used.

 For more information about the battery, launch the DJI GO 4 app and check the information that is listed under the battery tab.

## Charging the Intelligent Flight Battery

1. Connect the Battery Charger to a power source (100-240 V 50/60 Hz).
2. Connect one end of the charger to the Intelligent Flight Battery to the Battery Charger. If the battery level is above 95%, turn on the battery before charging.
3. The Battery Level Indicator will display the current battery level as it is charging.
4. The Intelligent Flight Battery is fully charged when the Battery Level Indicators are all off.
5. Air-cool the Intelligent Flight Battery after each flight. Allow its temperature to drop to room temperature before storing it for an extended period.

-  • Always turn off the battery before inserting it or removing it from the Phantom 4. Never insert or remove a battery when it is turned on.

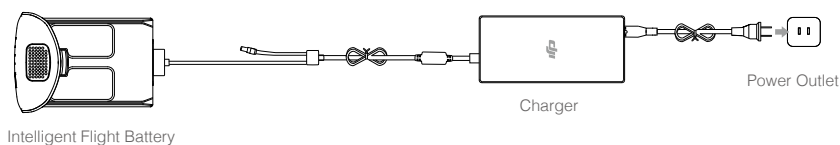

| Battery Level Indicators While Charging |      |      |      |               |
|---|------|------|------|---------------|
| LED1                                    | LED2 | LED3 | LED4 | Battery Level |
|   |      |      |      | 0%~25%        |
|   |      |      |      | 25%~50%       |
|   |      |      |      | 50%~75%       |
|   |      |      |      | 75%~100%      |
|   |      |      |      | Fully Charged |

## Battery Protection LED Display

The table below shows battery protection mechanisms and corresponding LED patterns.

| Battery Level Indicators while Charging |      |      |      |                                    |                                  |
|---|------|------|------|------------------------------------|----------------------------------|
| LED1                                    | LED2 | LED3 | LED4 | Blinking Pattern                   | Battery Protection Item          |
|   |      |      |      | LED2 blinks twice per second       | Over current detected            |
|   |      |      |      | LED2 blinks three times per second | Short circuit detected           |
|   |      |      |      | LED3 blinks twice per second       | Over charge detected             |
|   |      |      |      | LED3 blinks three times per second | Over-voltage charger detected    |
|   |      |      |      | LED4 blinks twice per second       | Charging temperature is too low  |
|   |      |      |      | LED4 blinks three times per second | Charging temperature is too high |



After these issues are resolved, press the Power Button to turn off the Battery Level Indicator. Unplug the Intelligent Flight Battery from the charger and plug it back in to resume charging. Note that you do not need to unplug and plug in the charger in the event of a room temperature error; the charger will resume charging when the temperature is within the allowable range.



DJI does not take any responsibility for damage caused by third-party chargers.

---



**How to discharge your Intelligent Flight Battery:**

**Slow** : Place the Intelligent Flight Battery into the Phantom 4's Battery Compartment and turn it on. Leave it on until there is less than 8% of power left, or until the battery can no longer be turned on. Launch the DJI GO 4 app to check battery levels.

**Rapid** : Fly the Phantom 4 outdoors until there is less than 8% of power left, or until the battery can no longer be turned on.

---

# Remote Controller

---

This section describes the features of the remote controller and includes instructions for controlling the aircraft and the camera.

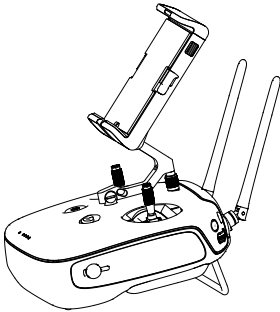

# Remote Controller

## Remote Controller Profile

The Phantom 4 remote controller is a multi-function wireless communication device that integrates the video downlink system and aircraft remote control system. The video downlink and aircraft remote control system operate at 2.4 GHz. The remote controller features a number of camera control functions, such as taking and previewing photos and videos, as well as controlling gimbal motion. The battery level is displayed via LED indicators on the front panel of the remote controller.

- ☰ • **Compliance Version:** The remote controller is compliant with local compliance and regulations.
- **Operating Mode:** Control can be set to Mode 1 or Mode 2, or to a custom mode.
  - **Mode 1:** The right stick serves as the throttle.
  - **Mode 2:** The left stick serves as the throttle.

⚠ To prevent transmission interference, do not operate more than three aircrafts in the same area.

## Using the Remote Controller

### Turning the Remote Controller On and Off

The Phantom 4 remote controller is powered by a 2S rechargeable battery that has a capacity of 6000 mAh. The battery level is indicated via the Battery Level LEDs on the front panel. Follow the steps below to turn on your remote controller:

1. When the remote controller is turned off, press the Power Button once. The Battery Level LEDs will display the current battery level.
2. Press and hold the Power Button to turn on the remote controller.
3. The remote controller will beep when it is turned on. The Status LED will rapidly blink green, indicating that the remote controller is linking to the aircraft. The Status LEDs will glow solid green when linking is complete.
4. Repeat Step 2 to turn off the remote controller.

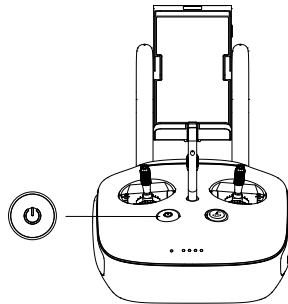

### Charging the Remote Controller

Charge the remote controller using the included charger. Refer to the figure on next page below for more details.

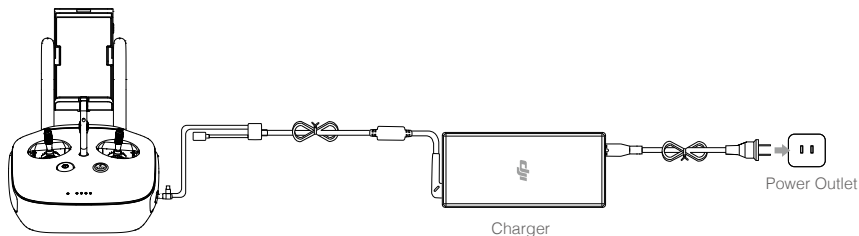

### Controlling the Camera

Shoot videos/pictures, view recorded images, and adjust camera settings via the Shutter Button, Camera Settings Dial, Playback Button, and Video Recording Button on the remote controller.

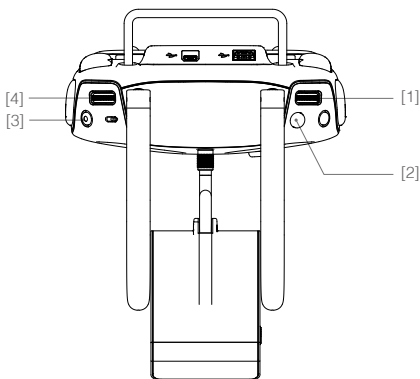

#### [1] Camera Settings Dial

Turn the dial to adjust camera settings such as ISO, shutter speed, and aperture without letting go of the remote controller. Press down on the dial to toggle between these settings.

#### [2] Shutter Button

Press to take a photo. If burst mode is activated, multiple photos will be taken with a single press.

#### [3] Video Recoding Button

Press once to start recording video, then press again to stop recording.

#### [4] Gimbal Dial

Use this dial to control the tilt of the gimbal.





### Controlling Aircraft

This section explains how to control the orientation of the aircraft through the remote controller. The Remote Control is set to Mode 2 by default.

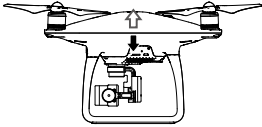
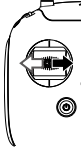
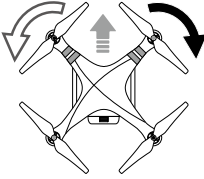

Stick Neutral/Mid-Point: Control sticks are in the center position.

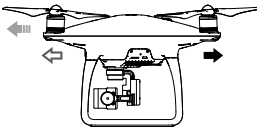
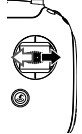
Moving the Control Stick: The control stick is pushed away from the center position.

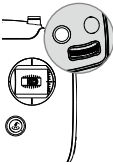
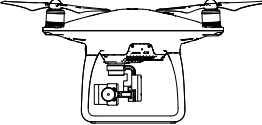
| Remote Controller<br>(Mode 2)  | Aircraft<br>(← Indicates Nose Direction)  | Remarks   |
|--|---|---|
|   |    | <p>Moving the left stick up and down changes the aircraft's elevation.</p> <p>Push the stick up to ascend and down to descend. When both sticks are centered, the Phantom 4 will hover in place.</p> <p>The more the stick is pushed away from the center position, the faster the Phantom 4 will change elevation. Always push the stick gently to prevent sudden and unexpected elevation changes.</p>                |
|   |    | <p>Moving the left stick to the left or right controls the rudder and rotation of the aircraft.</p> <p>Push the stick left to rotate the aircraft counter-clockwise, push the stick right to rotate the aircraft clockwise. If the stick is centered, the Phantom 4 will maintain its current orientation.</p> <p>The more the stick is pushed away from the center position, the faster the Phantom 4 will rotate.</p> |
|   |    | <p>Moving the right stick up and down changes the aircraft's forward and backward pitch.</p> <p>Push the stick up to fly forward and down to fly backward. Phantom 4 will hover in place if the stick is centered.</p> <p>Push the stick further away from the center position for a larger pitch angle (maximum 30°) and faster flight.</p>  |
|  |   | <p>Moving the right stick control left and right changes the aircraft's left and right pitch.</p> <p>Push left to fly left and right to fly right. The Phantom 4 will hover in place if the stick is centered.</p>  |
|  |  | <p>Press the Intelligent Flight Pause button once to exit from the ActiveTrack, TapFly and Intelligent Navigation flight mode. The aircraft will hover at the current position.</p>   |

**Adjusting Controller Sticks**

Hold and twist the controller sticks clockwise or counter clockwise to adjust the length of the controller sticks. A proper length of controller sticks can improve the controlling accuracy.

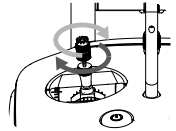

**Flight Mode Switch**

Toggle the switch to select the desired flight mode. You may choose between; P-mode, S-mode and A-mode.

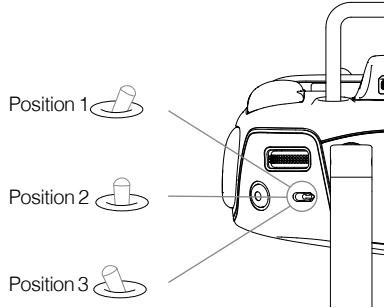

| Position   | Figure | Flight Mode |
|------------|--------|-------------|
| Position 1 |        | P-mode      |
| Position 2 |        | S-mode      |
| Position 3 |        | A-mode      |

Remote Controller

**P-mode (Positioning):** P-mode works best when the GPS signal is strong. The aircraft utilizes the GPS and Obstacle Sensing System to automatically stabilize itself, navigate between obstacles or track a moving object. Advanced features such as TapFly and ActiveTrack are enabled in this mode.

**S-mode (Sport):** The handling gain values of the aircraft are adjusted in order to enhance the maneuverability of the aircraft in S-mode. The maximum flight speed of the aircraft is increased to 20 m/s in this mode. Note that Obstacle Sensing system is disabled in this mode.

**A-mode (Attitude):** When neither the GPS nor the Obstacle Sensing System is available, the aircraft will only use its barometer for positioning to control the altitude.

**RTH Button**

Press and hold the RTH button to start the Return-to-Home (RTH) procedure. The LED ring around the RTH Button will blink white to indicate that the aircraft is entering RTH mode. The aircraft will then return to the last recorded Home Point. Press this button again to cancel the RTH procedure and regain control of the aircraft.

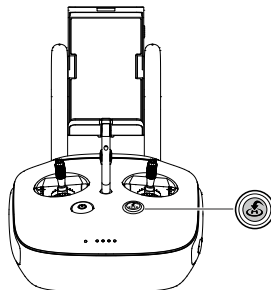

## Connecting Your Mobile Device

Tilt the mobile device holder to the desired position. Press the button on the side of the mobile device holder to release the clamp, and then place your mobile device into the cradle. Adjust the clamp down to secure the mobile device. To connect your mobile device to the remote controller using a USB cable, plug one end of the cable into your mobile device and the other end into the USB port on the back of the remote controller.

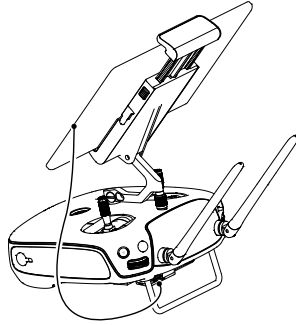

## Optimal Transmission Range

The transmission signal between the aircraft and the remote controller is most reliable within the area that is depicted in the image below:

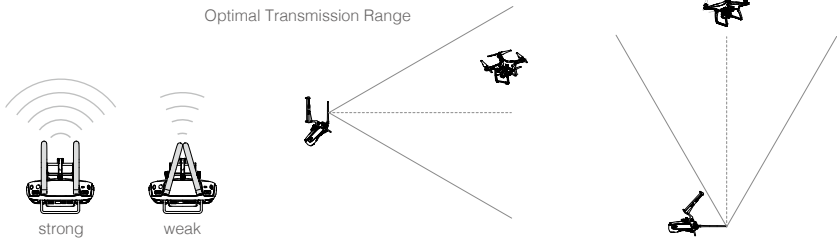







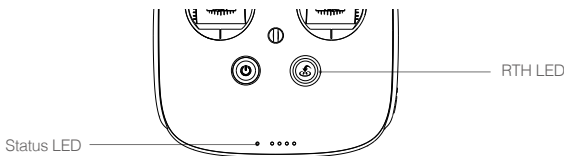





Ensure that the aircraft is flying within the optimal transmission zone. To achieve the best transmission performance, maintain the appropriate relationship between the operator and the aircraft.

## Remote Controller Status LED

The Status LED reflects the strength of the connection between the remote controller and the aircraft. The RTH LED indicates the Return-to-Home status of the aircraft. The table below contains more information about these indicators.



| Status LED   | Alarm   | Remote Controller Status                                 |
|--|---|--|
|  — Solid Red   |  Chime | The remote controller is disconnected from the aircraft. |
|  — Solid Green   |  Chime | The remote controller is connected to the aircraft.      |
|  ..... Slow Blinking Red   | D-D-D.....  | Remote controller error.                                 |
|  /  .....<br>Red and Green/ Red and Yellow Alternate Blinks | None  | HD downlink is disrupted.                                |
| RTH LED  | Sound   | Remote Controller Status                                 |
|  — Solid White   |  Chime | Aircraft is returning home.                              |
|  ..... Blinking White  | D . . .   | Sending Return-to-Home command to the aircraft.          |
|  ..... Blinking White  | DD . . . .  | Return-to-Home procedure in progress.                    |
|  The Remote Status Indicator will blink red and sound an alert, when the battery level is critically low.                                    |   |  |

## Linking the Remote Controller

The remote controller is linked to your aircraft before delivery. Linking is only required when using a new remote controller for the first time. Follow these steps to link a new remote controller:

1. Turn on the remote controller and connect to the mobile device. Launch the DJI GO 4 app.
2. Turn on the Intelligent Flight Battery.
3. Enter “Camera” and tap on  and then tap “Linking RC” button as shown below.

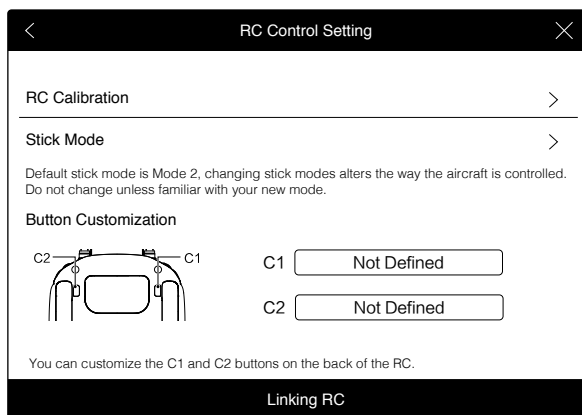



4. The remote controller is ready to link. The Remote Controller Status Indicator blinks blue and a beep is emitted.

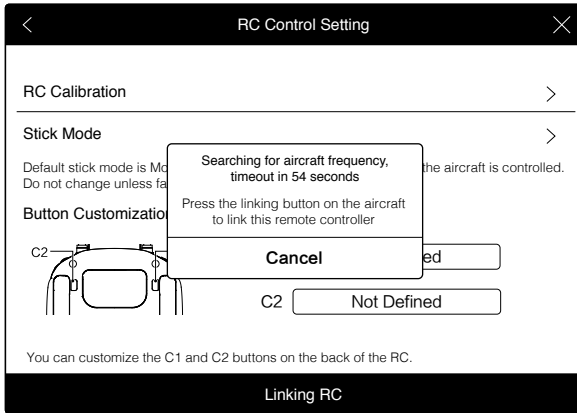

5. Locate the linking button on the side of the aircraft, as shown in the figure below. Press the link button to start linking. The Remote Controller Status Indicator LED will display a solid green once the remote controller is successfully linked to the aircraft.

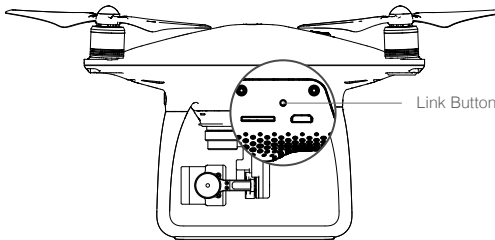

- The remote controller will un-link itself from an aircraft if a new remote controller is linked to the same aircraft.

# Camera and Gimbal

---

This section provides the technical specifications of the camera and explains the gimbal's operation modes.

# Camera and Gimbal

## Camera Profile

The on-board camera uses the 1/2.3 inch CMOS sensor to capture video (up to 4096x2160p at 24fps or 4K at up to 30 fps with the Phantom 4 and 12 megapixel stills). You may choose to record the video in either MOV or MP4 format. Available picture shooting modes include burst, continuous, and time-lapse mode. A live preview of what the camera sees can be monitored on the connected mobile device via the DJI GO 4 app.

### Camera Micro SD Card Slot

To store your photos and videos, insert the Micro SD card into the slot, as shown below, before turning on the Phantom 4. The Phantom 4 comes with a 16 GB Micro SD card and supports Micro SD cards up to 64 GB. A UHS-1 Micro SD card is recommended due to their fast read and write speeds allowing you to save high-resolution video data.

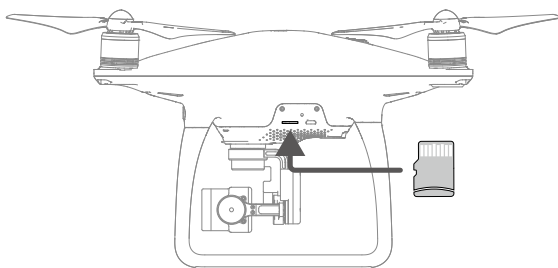

---

⊘ Do not remove the Micro SD card from the Phantom 4 when it is turned on.

---

☀ To ensure the stability of the camera system, single video recordings are capped at 30 minutes.

---

### Camera Data Port

Turn on the Phantom 4 and connect a USB cable to the Camera Data Port to download photos and videos to your computer.

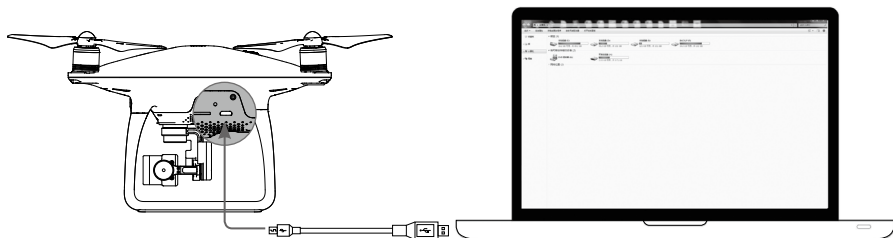

---

⚠ The aircraft must be turned on before attempting to access the files on the Micro SD card.









---

## Camera Operation

Use the Shutter and Video Recording buttons on the remote controller to shoot the images or videos through the DJI GO 4 app. For more information about how to use these buttons, refer to “Controlling the Camera Page 31”.

## Camera LED Indicator

Camera LED Indicator lights up after the flight battery is powered on. It provides information on the working status of the camera.

| Camera LED Indicator   | Camera status                  |
|--|--------------------------------|
|  Green Fast Blink (0.2s off, 0.1s on )                   | System is warming up.          |
|  Green Blink Once (0.5s off, 0.4s on )                   | Taking a single picture.       |
|  Green Blink 3 Times (0.3s off, 0.1s on )                | Taking 3 or 5 photos per shot. |
|  Slow Red Blink (1.6s on, 0.8s off )                     | Recording.                     |
|  Fast Red Blink (0.5s off, 0.2s on )                     | SD card error.                 |
|  Double Red Blink (0.1s on, 0.1s off, 0.1s on, 0.1s off) | Overheated Camera              |
|  Solid Red   | System error.                  |
|  Green and Red Blink (0.8s green on, 0.8s red on)        | Firmware Upgrading             |

## Gimbal

### Gimbal Profile



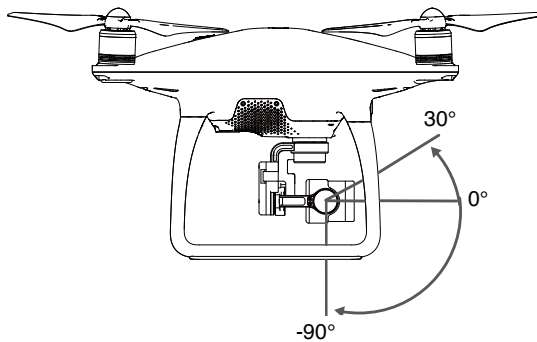

The 3-axis gimbal provides a steady platform for the attached camera, allowing you to capture clear, stable images and video. The gimbal can tilt the camera within a 120° range.



Use the gimbal dial on the remote controller to control the tilt movement of the camera.

## Gimbal Operation Modes

Two gimbal operation modes are available. Switch between the different operation modes on the camera settings page of the DJI GO 4 app. Note that your mobile device must be connected to the remote controller for changes to take effect. Refer to the table below for details:

|  |   |  |
|--|---|--|
|  |  Follow Mode   | The angle between gimbal's orientation and aircraft's nose remains constant at all times.                              |
|  |  FPV Mode  | The gimbal will synchronize with the movement of the aircraft to provide a first-person perspective flying experience. |
|  | <ul style="list-style-type: none"> <li>• A gimbal motor error may occur in these situations:               <ol style="list-style-type: none"> <li>(1) the aircraft is placed on uneven ground or the gimbal's motion is obstructed</li> <li>(2) the gimbal has been subjected to an excessive external force, such as a collision. Please take off from flat, open ground and protect the gimbal at all times.</li> </ol> </li> <li>• Flying in heavy fog or clouds may make the gimbal wet, leading to temporary failure. The gimbal will recover full functionality after it dries.</li> <li>• It is normal for the gimbal to produce short pulse of beeping tone upon initialization.</li> </ul> |  |

## DJI GO 4 app

---

This section introduces the four main functions of the DJI GO 4 app.

# DJI GO 4 App

The DJI GO 4 app is a mobile application designed specifically for DJI equipment. Use this app to control the gimbal, camera, and other aircraft functions. The app features Equipment, Editor, Explorer and Me sections, which are used for configuring your aircraft, editing and sharing your photos and videos with others. It is recommended that you use a tablet for the best experience.

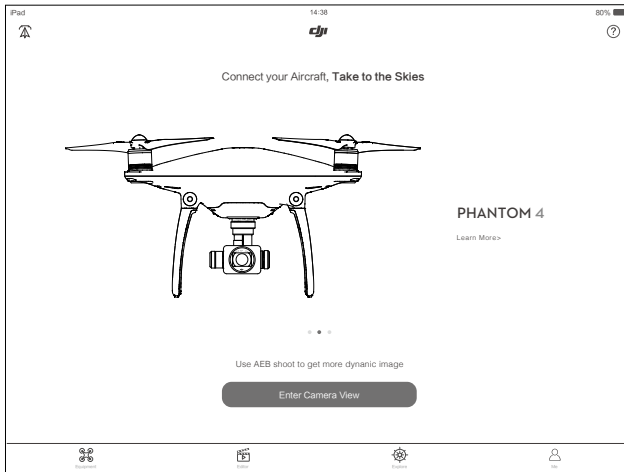

DJI GO 4 App

## Equipment

On the Equipment page, you can enter Camera View, visit the Academy or view your flight records.

### Camera View

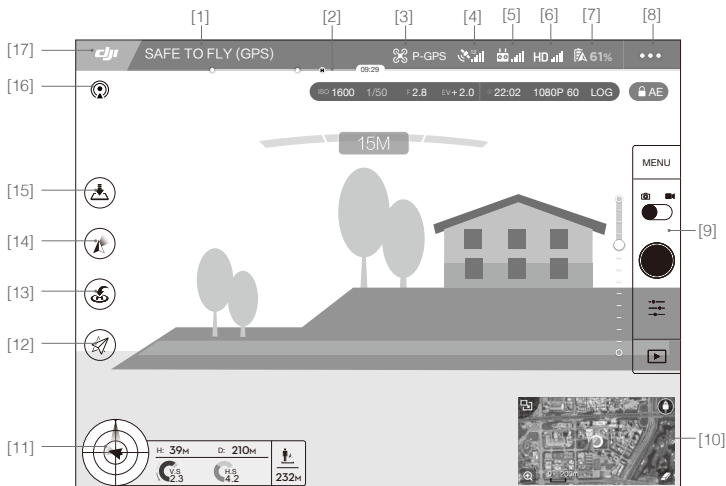

[1] System Status

 : Indicates the current aircraft system status and GPS signal strength.

[2] Battery Level Indicator

 : Describes the battery level of the aircraft according to its immediate status. The colored zones represent the various stages of battery level. When the battery level drops to a certain stage, the system will prompt the user to take the appropriate action.

[3] Flight Mode

 : The text next to this icon indicates the current flight mode.  
Tap this icon to configure the Main Controller Settings, to change the flight limits and set the gain values.

[4] GPS Signal Strength

 : Shows the current GPS signal strength. White bars indicate adequate GPS strength.

[5] Remote Controller Signal

 : Shows the signal strength of the remote controller.

[6] HD Video Link Signal Strength

 : Shows the signal strength of the HD video downlink between the aircraft and the remote controller.

[7] Battery Level

 **61%** : Shows the current battery level.  
Tap this icon to view the battery information menu where you can set the battery warning thresholds and view the battery log.

[8] General Settings

 : Tap this icon to view General Settings where you can set the flight parameters, and enable the Flight Route display.

[9] Camera Operation Bar

The bar will be displayed when using the on-board camera.

**Shutter and Recording Settings**

**MENU** : Tap this icon to enter various camera value settings including the Color Mode, Video Size, and Image Size.

**Shutter**

 : Tap this button to take a single photo. Press and hold this button to switch between Single Shot, Triple Shot and Timed Shot modes.

**Record**

 : Tap once to start recording video, then tap again to stop recording. You can also press the Video Recording Button on the remote controller.

**Playback**

 : Tap this icon to play back photos and videos after they are captured.



## Camera Settings

: Tap this icon to set the ISO, Shutter Speed and Exposure Value of the camera.

### [10] Mini Map

Displays the flight path of the current flight. Tap the Mini Map to switch between Camera View and Map View.



### [11] Flight Telemetry

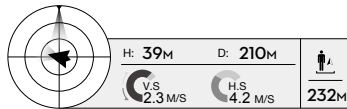

#### Flight Attitude and Radar Function:

The aircraft's flight attitude is indicated by the target-like icon.

(1) The red arrow shows which direction the aircraft is facing.

(2) The ratio of the grey area to the blue area indicates the aircraft's pitch.

(3) The horizontal level of the grey area indicates the aircraft's roll angle.

#### Flight Parameters:

Altitude: Vertical distance from the Home Point.

Distance: Horizontal distance from the Home Point.

Vertical Speed: Movement speed across a vertical distance.

Horizontal Speed: Movement speed across a horizontal distance.

#### Aircraft Distance:

The horizontal distance between the aircraft and the operator.

### [12] Intelligent Flight Mode



: This icon displays the Intelligent Flight Mode settings when the aircraft has entered F-mode. Tap to select one of the Intelligent Flight Modes. Refer to Intelligent Flight Modes (p. 62) for details.

### [13] Return-to-Home (RTH)

: Initiate RTH home procedure. Tap to have the aircraft return to the latest Home Point.

### [14] Gimbal Operation Mode

This icon will be displayed when using a DJI gimbal (or camera). Tap to select a mode or re-align the gimbal.

|   |                    |  |
|---|--------------------|--|
|  | <b>Follow Mode</b> | The gimbal's orientation is aligned with the aircraft's nose. One user alone can control the pitch motion of the gimbal, but a second operator is required to control the yaw motion using a second remote controller. |
|  | <b>FPV Mode</b>    | The gimbal will lock to the movement of the aircraft to provide a First-Person-View flying experience.   |

[15] Auto Takeoff/Landing

 : Tap to initiate auto takeoff or landing.

[16] Livestream

 : This icon indicates the current video feed is being broadcast live on YouTube. Ensure that mobile data service is available on your mobile device.

[17] Back

 : Tap this icon to return to the main menu.

## Editor

An intelligent video editor is built into the DJI GO 4 app. After recording several video clips and downloading them to your mobile device, go to Editor on the home screen. You can then select a template and a specified number of clips which are automatically combined to create a short film that can be shared immediately.

## SkyPixel

Find out about our latest events, featured products and trending Skypixel uploads in the Explore page.

## Me

If you already have a DJI account, you will be able to participate in forum discussions, earn Credits in the DJI Store, and share your artwork with the community.

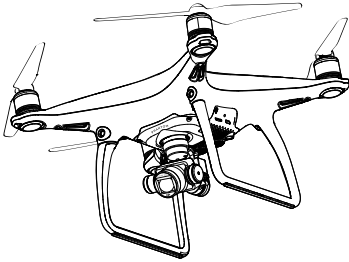

## Flight

---

This section describes safe flight practices and flight restrictions.

# Flight

Once pre-flight preparation is complete, it is recommended that you use the flight simulator in the DJI GO 4 app to hone your flight skills and practice flying safely. Ensure that all flights are carried out in an open area.

## Flight Environment Requirements

1. Do not use the aircraft in severe weather conditions. These include wind speeds exceeding 10 m/s , snow, rain and fog.
2. Only fly in open areas. Tall structures and large metal structures may affect the accuracy of the on-board compass and GPS system.
3. Avoid obstacles, crowds, high voltage power lines, trees, and bodies of water.
4. Minimize interference by avoiding areas with high levels of electromagnetism, including base stations and radio transmission towers.
5. Aircraft and battery performance is subject to environmental factors such as air density and temperature. Be very careful when flying at altitudes greater than 19, 685 feet (6000 meters) above sea level, as the performance of the battery and aircraft may be affected.
6. The Phantom 4 cannot operate within the polar areas.

## Flight Limits and No-Fly Zones

All unmanned aerial vehicle (UAV) operators should abide by all regulations set forth by government and regulatory agencies including the ICAO and the FAA. For safety reasons, flights are limited by default, which helps users operate this product safely and legally. Flight limitations include height limits, distance limits, and No-Fly Zones.

When operating in P-mode, height limits, distance limits, and No-Fly Zones function concurrently to manage flight safety. In A-mode, only height limits are in effect, which by default prevent the aircraft altitude from exceeding 1640 feet (500 m) .

### Maximum flight altitude & Radius Limits

Maximum flight altitude and radius limits may be changed in the DJI GO 4 app. Be aware that the maximum flight altitude cannot exceed 1640 feet (500 meters). In accordance with these settings, your Phantom 4 will fly in a restricted cylinder, as shown below:

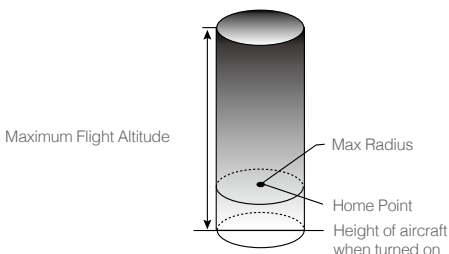

**GPS Signal Strong  .....Blinking Green**

|                         | Flight Limits  | DJI GO 4 app                     | Aircraft Status Indicator  |
|-------------------------|--|----------------------------------|--|
| Maximum Flight Altitude | Aircraft's altitude cannot exceed the specified value. | Warning: Height limit reached.   | None.  |
| Max Radius              | Flight distance must be within the max radius.         | Warning: Distance limit reached. | Rapid red flashing  ..... when close to the max radius limit. |

**GPS Signal Weak  .....Blinking Yellow**

|                         | Flight Limits   | DJI GO 4 app                   | Aircraft Status Indicator |
|-------------------------|---|--------------------------------|---------------------------|
| Maximum Flight Altitude | Height is restricted to 26 feet (8 meters) when the GPS signal is weak and Vision Positioning is activated. Height is restricted to 164 feet (50 meters) when the GPS signal is weak and Vision Positioning is inactivated. | Warning: Height limit reached. | None.                     |
| Max Radius              | No limits   |                                |                           |



- If the aircraft flies out of the limit, you can still control the aircraft, but you cannot fly it any farther.
- If the aircraft flies out of the max radius it will fly back within range automatically when GPS signal is strong.

## No-Fly Zones

All No-Fly Zones are listed on the DJI official website at <http://www.dji.com/flysafe/no-fly>. No-Fly Zones are divided into Airports and Restricted Areas. Airports include major airports and flying fields where manned aircraft operate at low altitudes. Restricted Areas include border lines between countries or sensitive institute. The details of the No-Fly Zones are explained as follow:

### Airport

- (1) Airport No-Fly Zone are comprised of Take-off Restricted zones and Restricted Altitude Zones. Each zone features circles of various sizes.
- (2) R1 miles (value of the R1 depends on the size and shape of the airport) around the airport is a Take-off restricted zone, inside of which take off is prevented.
- (3) From R1 mile to R1 + 1 mile around the airport the flight altitude is limited to a 15 degree inclination. Starting at 65 feet (20 meters) from the edge of airport and radiating outward. The flight altitude is limited to 1640 feet (500 meters) at R1+1 mile
- (4) When the aircraft enters within 320 feet (100 meters) of No-Fly Zones, a warning message will appear on the DJI GO 4 app.

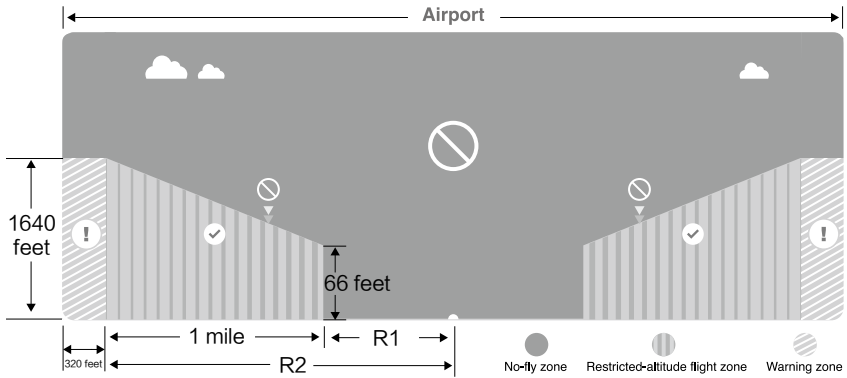





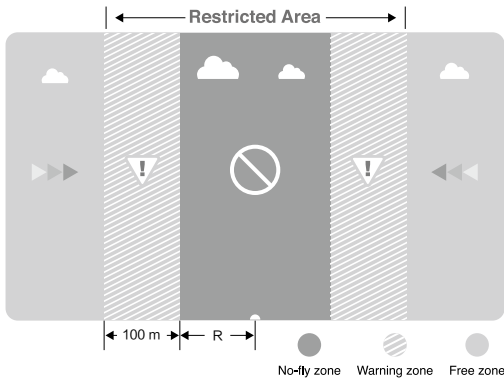

### Restricted Area

- (1) Restricted Areas does not have flight altitude restrictions.
- (2) R miles around the designated restriction area is a Take-off Restricted area. Aircraft cannot take off within this zone. The value of R varies based on the definition of the restricted areas.
- (3) A "warning zone" has been set around the Restricted Area. When the aircraft approaches within 0.062 miles (100 m) of this zone, a warning message will appear on the DJI GO 4 app.



Flight

| GPS Signal Strong  .....Blinking Green |   |  |   |
|---|---|--|---|
| Zone  | Restriction   | DJI GO 4 app Prompt  | Aircraft Status Indicator   |
| No-fly Zone<br>                        | Motors will not start.  | Warning: You are in a No-fly zone. Take off prohibited.  |  .....<br>Red flashing |
|   | If the aircraft enters the restricted area in A-mode, but is switched to P-mode, the aircraft will automatically descend, land, and stop its motors.                    | Warning: You are in a no-fly zone. Automatic landing has begun.  |   |
| Restricted-altitude flight zone<br>    | If the aircraft enters the restricted area in A-mode, but is switched to P-mode, it will descend to an appropriate altitude and hover 15 feet below the altitude limit. | R1: Warning: You are in a restricted zone. Descending to safe altitude.<br>R2: Warning: You are in a restricted zone. Maximum flight altitude is restricted to between 20m and 500m. Fly cautiously. |   |
| Warning zone<br>                       | No flight restriction applies, but there will be a warning .  | Warning: You are approaching a restricted zone, Fly cautiously.  |   |
| Free zone<br>                          | No restrictions.  | None.  |   |

 Semi-automatic descent: All stick commands are available except the left stick command during the descent and landing process. Motors will stop automatically after landing.

-  • When flying in a safety zone, the aircraft's status indicator will blink red rapidly and continue for 3 seconds, then switch to indicate current flying status and continue for 5 seconds at which point it will switch back to blinking red.
- For safety reasons, please do not fly close to airports, highways, railway stations, railway lines, city centers, or other sensitive areas. Fly the aircraft only within your line of sight.

## Preflight Checklist

1. Remote controller, Intelligent Flight Battery, and mobile device are fully charged.
2. Propellers are mounted correctly and firmly.
3. Micro SD card has been inserted, if necessary.
4. Gimbal is functioning normally.
5. Motors can start and are functioning normally.
6. The DJI GO 4 app is successfully connected to the aircraft.
7. Ensure that the sensors for the Obstacle Sensing System are clean.

## Calibrating the Compass

Only calibrate the compass when the DJI GO 4 app or the status indicator prompt you to do so. Observe the following rules when calibrating your compass:

- DO NOT calibrate your compass where there is a chance of strong magnetic interference, such as magnetite, parking structures, and steel reinforcements underground.
- DO NOT carry ferromagnetic materials with you during calibration such as cellular phones.
- The DJI GO 4 app will prompt you to resolve the compass issue if the compass is affected by strong interference after calibration is complete. Follow the prompted instructions to resolve the compass issue.

### Calibration Procedures

Choose an open area to carry out the following procedures.

1. Ensure that the compass is calibrated. If you did not calibrate the compass as part of your pre-flight preparations, or if you have moved to a new location since the last calibration, tap the Aircraft Status Bar in the app and select "Calibrate", then follow the on-screen instructions.
2. Hold the aircraft horizontally and rotate 360 degrees. The Aircraft Status Indicators will display a solid green light.

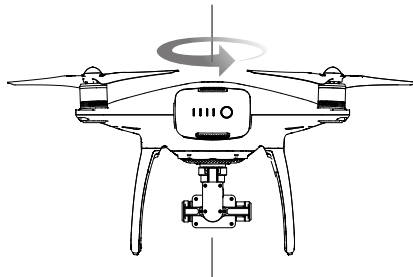

3. Hold the aircraft vertically, with nose pointing downward, and rotate it 360 degrees around the center axis. Recalibrate the compass if the Aircraft Status Indicator glows solid red.

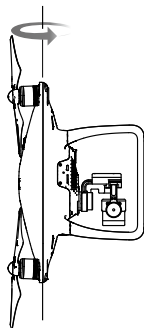



4. Re-calibrate the aircraft if the aircraft status indicators blink red.



- If the Aircraft Status Indicator blinks red and yellow after the calibration procedure, move your aircraft to a different location and try again.



- Calibrate the compass before each flight. Launch the DJI GO 4 app and follow the on-screen instructions to calibrate the compass. DO NOT calibrate the compass near metal objects such as a metal bridge, cars, scaffolding.
  - If the aircraft status indicators is blinking red and yellow alternately after placing the aircraft on the ground, the compass has detected magnetic interference. Change your location.
- 

### When to Recalibrate

1. When compass data is abnormal and the Aircraft Status Indicator is blinking green and yellow.
2. When flying in a new location or in a location that is different from the most recent flight.
3. When the mechanical or physical structure of the Phantom 4 has been changed.
4. When severe drifting occurs in flight, i.e. Phantom 4 does not fly in straight line.

## Auto Takeoff and Auto Landing

### Auto Takeoff

Use auto takeoff only if the Aircraft Status Indicators are blinking green. Follow the steps below to use the auto takeoff feature:

1. Launch the DJI GO 4 app, and enter "Camera" page.
2. Ensure the aircraft is in P- mode.
3. Complete all steps on the pre-flight checklist.
4. Tap "", and confirm that conditions are safe for flight. Slide the icon to confirm and takeoff.
5. Aircraft takes off and hovers at (1.2 meters) above ground.



Aircraft Status Indicator blinks rapidly when it is using the Vision Position System for stabilization. The aircraft will automatically hover below 3 meters. It is recommended to wait until there is sufficient GPS lock before using the Auto Take-off feature.

---

### Auto-Landing

Use auto-landing only if the Aircraft Status Indicators are blinking green. Follow the steps below to use the auto-landing feature:

1. Ensure the aircraft is in P- mode.
2. Check the landing area condition before tapping "", to begin landing. Then follow the on-screen instructions.

## Starting/Stopping the Motors

### Starting the Motors

A Combination Stick Command (CSC) is used to start the motors. Push both sticks to the bottom inner or outer corners to start the motors. Once the motors have started spinning, release both sticks simultaneously.

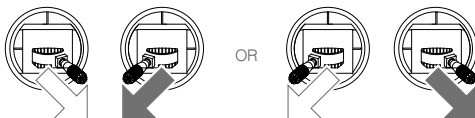

### Stopping the Motors

There are two methods to stop the motors.

Method 1: When Phantom 4 has landed, push the left stick down ①, then conduct the same CSC that was used to start the motors, as described above ②. Motors will stop immediately. Release both sticks once motors stop.

Method 2: When the aircraft has landed, push and hold the left stick down. The motors will stop after three seconds.

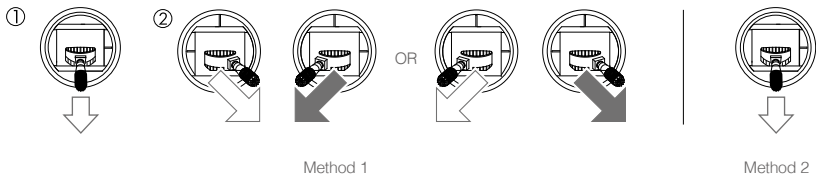

## Stop the motor mid-flight

Pull the left stick to the bottom inside corners and press the RTH button at the same time. **Only stop the motors mid-flight in emergency situations when doing so can reduce the risk of damage or injury. Refer to the user manual for details.**

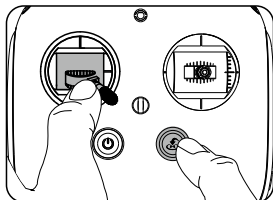

## Flight Test

### Takeoff/Landing Procedures

1. Place the aircraft in an open, flat area with the battery level indicators facing towards you.
2. Turn on the remote controller and your mobile device, then turn on the Intelligent Flight Battery.
3. Launch the DJI GO 4 app and enter the Camera page.
4. Wait until the Aircraft Indicators blink green. This means the Home Point is recorded and it is now safe to fly. If they flash yellow, the Home Point has not been recorded.
5. Push the left stick up slowly to take off or use Auto Takeoff.
6. Shoot photos and videos using the DJI GO 4 app.
7. To land, hover over a level surface and gently pull down on the left stick to descend.
8. After landing, execute the CSC command or hold the left stick at its lowest position until the motors stop.
9. Turn off the Intelligent Flight Battery first, then the Remote Controller.



- When the Aircraft Status Indicators blink yellow rapidly during flight, the aircraft has entered Failsafe mode.
  - A low battery level warning is indicated by the Aircraft Status Indicators blinking red slowly or rapidly during flight.
  - Watch our video tutorials for more flight information.
- 

### Video Suggestions and Tips

1. Go through the full pre-flight checklist before each flight.
2. Select the desired gimbal operation mode in the DJI GO 4 app.
3. Only shoot video when flying in P-mode.
4. Always fly in good weather and avoid flying in rain or heavy wind.
5. Choose the camera settings that suit your needs. Settings include photo format and exposure compensation.
6. Perform flight tests to establish flight routes and preview scenes.
7. Push the control sticks gently to keep the aircraft's movement smooth and stable.

# FAQ

---

# FAQ

## What is ActiveTrack?

ActiveTrack allows an aircraft to track a moving subject without a separate GPS tracker. Simply tap on the mobile device screen inside the DJI GO 4 app to select the subject to be tracked. The aircraft will lock on the subject and start tracking it automatically from a safe distance.

## What is TapFly?

TapFly means you can fly in any direction with a tap of the finger, without a remote controller. With Obstacle Avoidance turned on, the aircraft will automatically avoid obstacles, slow down or hover when required, provided that the scene is bright enough (< 300 lux) or too bright (> 10,000 lux).

## What is the Phantom 4 Obstacle Sensing System?

The Phantom 4 is equipped with an Obstacle Sensing System that constantly scans for obstacles in front of it, allowing it to avoid collisions by going around, over or hovering.

## Why does the Phantom 4 have a magnesium core?

The revolutionary magnesium core embedded into the aircraft greatly increases rigidity, minimizing unwanted vibrations. This ensures the precision and performance of the inertial measurement unit (IMU). The weight of the aircraft is also reduced through this magnesium core.

## What changes were made to the Phantom 4 remote?

The Phantom 4 introduces a Sport mode, accessible through a new trio of modes, P, S and A.

P (Position) mode is the standard mode, giving access to normal flight as well as Intelligent Flight Modes, ActiveTrack and TapFly.

S (Sport) Mode unlocks maximum flight speeds of up to 44mph (72kmh).

A (Attitude) Mode remains the same and removes satellite stabilization in flight. It allows the Phantom to move more smoothly and naturally.

The 'Playback' button on the top right of the remote controller has been changed into a 'Pause' button that lets you put the Phantom into hover during any Intelligent Flight Mode, ActiveTrack or TapFly with a tap.

## What improvements have been made to the Phantom 4 Vision Positioning Unit?

The Vision Positioning System now uses four sensors to increase hovering accuracy and reliability, creating a more controlled flying experience. Its sonar system has been improved and now functions from up to 10 meters off the ground. In ideal situations, these combine to give the Phantom 4 Vision Positioning System a vertical hover accuracy of +/- 0.1 m and a horizontal hover accuracy of +/- 0.3 m.

## What is the effective range of the Obstacle Sensing System on Phantom 4?

The effective range of the Obstacle Sensing System is 0.7 to 15 meters. Although the DJI GO 4 app will indicate when there are obstacles present, pilots should always be paying attention to the aircraft during flight.

**Does Obstacle Sensing System work in all modes?**

The Obstacle Sensing System can be enabled in ActiveTrack, TapFly, Normal mode and all Intelligent Navigation functions.

**What are the major improvements in the Phantom 4 propulsion system?**

The motor on the Phantom 4 is designed to work with the latest Push-and-Release Propellers. With this locking mechanism, propellers can withstand drastic changes of motor speed, allowing the aircraft to be more agile and more responsive to the pilot command.

**How many minutes of flight time can Phantom 4 achieve with the new Intelligent Flight Battery?**

At sea level in calm environments when flying in ATTI mode, the Phantom 4 can achieve 28 minute flight times. This will vary due to different flight patterns, weather conditions and altitudes.

**What are the major differences between the Phantom 4 propellers and the Phantom 3 ones?**

The new Push-and-Release propellers are faster to install and more secure than the Self Tightening propellers used previously. This security allows them to handle faster acceleration and harder braking.

**What makes the Phantom 4 gimbal better?**

The gimbal and camera system is integrated into the body, bringing it closer to the aircraft's center of gravity. It is also made of a rigid and strong composite material.

**What makes the Phantom 4 camera better?**

The Phantom 4 camera has been improved in terms of image quality. Chromatic aberration has been reduced by 56% and lens distortion had been reduced by 36% compared to Phantom 3 Professional. In addition to lens improvements, camera firmware has been tweaked to enable the camera to capture 120fps video in full 1080p FHD (the camera's field of view will be reconfigured to 47° when recording in this mode) for smooth slow motion.

**Why add a redundant IMU and compass to the Phantom 4?**

A redundant IMU and compass enhances system reliability. The Phantom 4 can constantly compare data received from both IMUs and then navigate itself using the most accurate data. The same is true of the redundant compasses.

**What are the highlights of the Phantom 4 remote control and live feed?**

The Phantom 4's remote control and live feed is based on DJI Lightbridge technology, providing effective control range of up to 3.1mi (5km) in unobstructed areas that are free from interference. Its HD live feed gives you an exact view of your flight, perfect for composing shots.

**Does the Phantom 4 have Return-to-Home?**

Yes. It also has Smart Return Home which engages the Obstacle Sensing System during return to home flight. If the aircraft sees an obstacle on its way back, it will intelligently avoid it as it comes home.

**What's the purpose of the Sport Mode?**

Giving a top speed of 44.7mph (72Kph), Sport mode can be used for fun, letting you fly faster than ever, or to get to your shoot location while the light is perfect.

**What's the horizontal speed of Phantom 4 in ATTI Mode?**

The horizontal speed of the Phantom 4 in ATTI mode is 35.8mph (57.6kph).

**What is the difference between Sport Mode and ATTI Mode?**

Though Phantom 4 can fly up to 44.7mph in both Sport Mode and ATTI Mode, Phantom 4 will use GPS/Glonass and its Vision Positioning System to achieve precision while hovering. In ATTI Mode, GPS and Vision Positioning System will not function to aid the aircraft in terms of hovering or navigation.

**In ActiveTrack, how do you untrack the subject? What happens to the aircraft after you stop tracking?**

Tap the Stop button on the left of the screen or pull the pitch stick backward for 3 seconds to exit ActiveTrack. After exiting, the aircraft will hover in place. At this point you may choose to start a new mission or bring the aircraft back to the Home Point.

**How small an object can the Obstacle Sensing System see?**

The minimum pixel size that the Obstacle Sensing system can see is 500 pixels.

**What is ActiveTrack's minimum altitude?**

ActiveTrack will work down to 9ft (3m) above the ground.

# Appendix

---



# Appendix

## Specifications

### Aircraft

|  |  |
|--|--|
| Weight (Battery & Propellers Included) | 1380 g   |
| Max Ascent Speed                       | 6 m/s ( Sport mode )   |
| Max Descent Speed                      | 4 m/s ( Sport mode )   |
| Max Speed                              | 20 m/s ( Sport mode )  |
| Max Service Ceiling Above Sea Level    | 19685 feet ( 6000 m )<br>( Software altitude limit: 400 feet above takeoff point ) |
| Max Flight Time                        | Approx. 28 minutes   |
| Operating Temperature Range            | 32° to 104° F ( 0° to 40° C )  |
| Satellite Systems                      | GPS/GLONASS  |

### Gimbal

|                    |                       |
|--------------------|-----------------------|
| Controllable Range | Pitch: - 90° to + 30° |
|--------------------|-----------------------|

### Obstacle Sensing System

|                        |   |
|------------------------|---|
| Obstacle Sensory Range | 2 - 49 feet ( 0.7 - 15 m )                                    |
| Operating Environment  | Surface with clear pattern and adequate lighting ( lux > 15 ) |

### Vision Positioning System

|                       |  |
|-----------------------|--|
| Velocity Range        | ≤10 m/s ( 2 m above ground )                                     |
| Altitude Range        | 0 - 33 feet ( 0 - 10 m )   |
| Operating Range       | 0 - 33 feet ( 0 - 10 m )   |
| Operating Environment | Surfaces with a clear pattern and adequate lighting ( lux > 15 ) |

### Camera

|                          |   |
|--------------------------|---|
| Sensor                   | 1/2.3" Effective pixels:12 M  |
| Lens                     | FOV ( Field Of View ) 94° 20 mm ( 35 mm format equivalent )<br>f/2.8 focus at ∞ |
| ISO Range                | 100-3200(video) 100-1600(photo)   |
| Electronic Shutter Speed | 8 s to 1/8000 s   |
| Max Image Size           | 4000 x 3000   |

|                         |   |
|-------------------------|---|
| Still Photography Modes | Single shot   |
|                         | Burst shooting: 3/5/7 frames  |
|                         | Auto Exposure Bracketing (AEB):<br>3/5 Bracketed frames at 0.7EV Bias |
|                         | Time-lapse<br>HDR   |

|                       |   |
|-----------------------|---|
| Video Recording Modes | UHD: 4096×2160 (4K) 24 / 25p                      |
|                       | 3840×2160 (4K) 24 / 25 / 30p                      |
|                       | 2704×1520 (2.7K) 24 / 25 / 30p                    |
|                       | FHD: 1920×1080 24 / 25 / 30 / 48 / 50 / 60 / 120p |
|                       | HD: 1280×720 24 / 25 / 30 / 48 / 50 / 60p         |

|                               |         |
|-------------------------------|---------|
| Max. Bitrate Of Video Storage | 60 Mbps |
|-------------------------------|---------|

|                        |   |
|------------------------|---|
| Supported File Systems | FAT32 ( ≤ 32 GB ); exFAT ( > 32 GB )                            |
| Photo                  | JPEG, DNG ( RAW )   |
| Video                  | MP4 / MOV ( MPEG – 4 AVC / H.264 )                              |
| Supported SD Cards     | Micro SD, Max capacity: 64GB. Class 10 or UHS-1 rating required |
| Operating Temperature  | 32° to 104° F ( 0° to 40° C )                                   |

### Remote Controller

|                            |   |
|----------------------------|---|
| Operating Frequency        | 2.400 GHz to 2.483 GHz  |
| Max Transmission Distance  | FCC Compliant: 3.1 mi ( 5 km ); CE Compliant: 2.2 mi ( 3.5 km )<br>( Unobstructed, free of interference ) |
| Operating Temperature      | 32° to 104° F ( 0° to 40° C )   |
| Battery                    | 6000 mAh LiPo 2S  |
| Mobile Device Holder       | Tablets and smartphones   |
| Transmitter Power ( EIRP ) | FCC: 23 dBm; CE: 17 dBm   |
| Operating Voltage          | 7.4V @ 1.2A   |

### Charger





|             |        |
|-------------|--------|
| Voltage     | 17.4 V |
| Rated Power | 100 W  |

### Intelligent Flight Battery ( PH4 - 5350 mAh -15.2 V )







|                       |                                 |
|-----------------------|---------------------------------|
| Capacity              | 5350 mAh                        |
| Voltage               | 15.2 V                          |
| Battery Type          | LiPo 4S                         |
| Energy                | 81.3 Wh                         |
| Net Weight            | 462 g                           |
| Operating Temperature | 14° to 104° F ( -10° to 40° C ) |
| Max. Charging Power   | 100 W                           |

## Aircraft Status Indicator Description

### Normal

|  |  |
|--|--|
|  ..... Red, Green and Yellow Flash Alternately | Turning on and Self-Diagnostics                              |
|  ..... Green and Yellow Flash Alternately      | Aircraft Warming Up  |
|  ..... Green Flashes Slowly                    | Safe to Fly (P-mode with GPS and Vision Positioning)         |
|  ..... Green Flashes Twice                     | Safe to Fly (P-mode with Vision Positioning but without GPS) |
|  ..... Yellow Flashes Slowly                   | Safe to Fly (A-mode but No GPS and Vision Positioning)       |

**Warning**

|   |                               |
|---|-------------------------------|
|  ..... Fast Yellow Flashing               | Remote Controller Signal Lost |
|  ..... Slow Red Flashing                  | Low Battery Warning           |
|  ..... Fast Red Flashing                  | Critical Battery Warning      |
|  ..... Red Flashing Alternatively         | IMU Error                     |
|  — Solid Red                              | Critical Error                |
|  ..... Red and Yellow Flash Alternatively | Compass Calibration Required  |

**Firmwares Update**

Use DJI Assistant 2 or DJI GO 4 app to update aircraft and remote controller. Follow the instructions below to update the firmware through DJI Assistant 2:

1. Connect the aircraft to a computer with a USB cable.
2. Launch DJI Assistant 2 and login with your DJI account.
3. Select "Phantom 4" and click on the "Firmware Updates" on the left panel.
4. Select the firmware version that you wish to update.
5. Wait for the firmware to be downloaded and firmware update will start automatically.
6. Reboot the aircraft after the firmware update is complete.

-  • The firmware update will take around 15 minutes. It is normal that the gimbal go limp, aircraft status indicator blinks abnormally and the aircraft reboots. Please wait patiently until the update is complete.
- There will be no sound prompts during the update.
- Ensure the computer has access to the Internet.
- Ensure the battery level is adequate for the Intelligent Flight Battery.
- Do not disconnect the aircraft from the computer during firmware update.

**Intelligent Flight Mode**

Intelligent Flight mode includes Course Lock, Home Lock, Point of Interest (POI), Follow Me and Waypoints features to assist users to create professional shoots during the flight. Course Lock and Home Point lock helps to lock the orientation of aircraft so that the user can focus more on other operations. Point of Interest, Follow Me and Waypoints mode enable aircraft to fly automatically according to the pre-set flight maneuvers.

|                   |   |
|-------------------|---|
| Course Lock       | Lock the current nose direction as the aircraft's forward direction. The aircraft will move in the locked directions regardless of its orientation (yaw angle).   |
| Home Lock         | Pull the pitch stick backward to move the aircraft toward its recorded Home Point.  |
| Point of Interest | The aircraft will orbit around the subject automatically to allow the operator can be more focus on framing their shoot on the subject in Point of Interest.  |
| Follow Me         | A virtual tether is created between the aircraft and the mobile device so that the aircraft can track your movement as you move. Note that Follow Me performance is subject to the GPS accuracy on the mobile device. |

|           |  |
|-----------|--|
| Waypoints | Record a flight path, then the aircraft will fly along the same path repeatedly while you control the camera and orientation. The flight path can be saved and re-apply in the future. |
|-----------|--|

Enable Multiple Flight Mode by launching the DJI GO 4 app > Camera View >  > Advanced Settings > Multiple Flight Mode before using the Intelligent Flight Mode for the first time.

## After-Sales Information

Visit the following pages to learn more about After-sales policy and warranty information:

1. After-sales Policy: <http://www.dji.com/service>
2. Refund Policy: <http://www.dji.com/service/refund-return>
3. Paid Repair Service: <http://www.dji.com/service/repair-service>
4. Warranty Service: <http://www.dji.com/service/warranty-service>

## FCC Compliance

### FCC Compliance

This device complies with part 15 of the FCC Rules. Operation is subject to the following two conditions:

- (1) This device may not cause harmful interference, and
- (2) This device must accept any interference received, including interference that may cause undesired operation.

Changes or modifications not expressly approved by the party responsible for compliance could void the user's authority to operate the equipment.

Compliance Information

### FCC Warning Message

Any changes or modifications not expressly approved by the party responsible for compliance could void the user's authority to operate the equipment.

This device complies with part 15 of the FCC Rules. Operation is subject to the following two conditions:

- (1) This device may not cause harmful interference, and
- (2) this device must accept any interference received, including interference that may cause undesired operation.

### FCC Radiation Exposure Statement:

This equipment complies with FCC radiation exposure limits set forth for an uncontrolled environment. This equipment should be installed and operated with minimum distance 20cm between the radiator& your body. This transmitter must not be co-located or operating in conjunction with any other antenna or transmitter.

Note: This equipment has been tested and found to comply with the limits for a Class B digital device, pursuant to part 15 of the FCC Rules. These limits are designed to provide reasonable protection against harmful interference in a residential installation. This equipment generates uses and can radiate radio frequency energy and, if not installed and used in accordance with the instructions, may cause harmful interference to radio communications. However, there is no guarantee that interference will not occur in a particular installation. If this equipment does cause harmful interference to radio or television reception, which can be determined by turning the equipment off and on, the user is encouraged to try to correct

the interference by one or more of the following measures:

- Reorient or relocate the receiving antenna.
- Increase the separation between the equipment and receiver.
- Connect the equipment into an outlet on a circuit different from that to which the receiver is connected.
- Consult the dealer or an experienced radio/TV technician for help.

### IC RSS warning

This device complies with Industry Canada licence-exempt RSS standard (s). Operation is subject to the following two conditions: (1) this device may not cause interference, and (2) this device must accept any interference, including interference that may cause undesired operation of the device.

Le présent ariel est conforme aux CNR d'Industrie Canada licenciables aux aereils radio exempts de licence.

L'exploitation est autorisée aux deux conditions suivantes:

- (1) l'areil ne doit pas produire de brouillage, et
- (2) l'utilisateur de l'areil doit accepter tout brouillage radioélectrique subi, même si le brouillage est susceptible d'en compromettre le fonctionnement.

### IC Radiation Exposure Statement:

This equipment complies with IC RF radiation exposure limits set forth for an uncontrolled environment. This transmitter must not be co-located or operating in conjunction with any other antenna or transmitter. This equipment should be installed and operated with minimum distance 20cm between the radiator & your body.

Any Changes or modifications not expressly approved by the party responsible for compliance could void the user's authority to operate the equipment.

### KCC Warning Message

“해당무선설비는 운용 중 전파혼신 가능성이 있으므로 인명안전과 관련된 서비스는 할 수 없습니다.”  
 “해당 무선설비는 운용 중 전파혼신 가능성이 있음”

### NCC Warning Message

低功率電波輻射性電機管理辦法

第十二條經型式認證合格之低功率射頻電機，非經許可，公司、商號或使用者均不得擅自變更頻率、加大功率或變更原設計之特性及功能。

第十四條低功率射頻電機之使用不得影響飛航安全及干擾合法通信；經發現有干擾現象時，應改善至無干擾時方得繼續使用。前項合法通信，指依電信法規定作業之無線電通信。低功率射頻電機須忍受合法通信或工業、科學及醫療用電波輻射性電機設備之干擾。

DJI Support  
<http://www.dji.com/support>

This content is subject to change.

**Download the latest version from**  
<http://www.dji.com/product/phantom-4>



If you have any questions about this document, please contact DJI by sending a message to [DocSupport@dji.com](mailto:DocSupport@dji.com).